

SEARS
OWNER'S
MANUAL

MODEL NO.
917.254450
AND
917.250020
WITHOUT
MOWER DECK

Caution:
Read and follow
all Safety Rules
and Instructions
Before Operating
This Equipment



CRAFTSMAN®
18.0 HP TWIN IC
ELECTRIC START
44" MOWER DECK
6 SPEED TRANSAXLE
GARDEN TRACTOR

- Assembly
- Operation
- Maintenance
- Service and Adjustment
- Repair Parts



LOOK FOR THIS SYMBOL TO POINT OUT IMPORTANT SAFETY PRECAUTIONS. IT MEANS - ATTENTION! BECOME ALERT! YOUR SAFETY IS INVOLVED.

CAUTION: LOOK FOR THIS WORD TO POINT OUT IMPORTANT EQUIPMENT PRECAUTIONS.

NOTE: LOOK FOR THIS WORD TO POINT OUT IMPORTANT INFORMATION ABOUT THE OPERATION AND PERFORMANCE OF YOUR TRACTOR.



RULES FOR SAFE OPERATION

WARNING: This unit is equipped with an internal combustion engine and should not be used on or near any unimproved forest covered, brush covered or grass covered land unless the engine's exhaust system is equipped with a spark arrester meeting applicable local or area laws (if any). If a spark arrester is used, it should be maintained in effective working order by the operator. (See REPAIR PARTS for part number identification).

In the State of California the above is required by law (Section 4442 of the California Public Resources Code). Other States may have similar laws. Federal laws apply on federal lands.

1. Know the controls and how to stop quickly. READ THIS OWNER'S MANUAL and instructions furnished with attachments.
2. Do not allow children to operate the machine. Do not allow adults to operate it without proper instruction.
3. Do not carry passengers. Do not mow when children and others are around.
4. Always wear substantial footwear. Do not wear loose fitting clothing that could get caught in moving parts.
5. Keep your eyes and mind on your tractor, mower, and the area being cut. Do not let other interests distract you.
6. Do not attempt to operate your tractor or mower when not in the driver's seat.
7. Always get on or off your tractor from the operator's left hand side.
8. Clear the work area of objects (wire, rocks, etc.) which might be picked up and thrown.
9. Disengage all attachment clutches before attempting to start the engine.
10. Disengage power to attachments and stop the engine before leaving the operator's position.
11. Disengage power to mower, stop the engine, and disconnect spark plug wire(s) from spark plug(s) before cleaning, making an adjustment, or repair. Be careful to avoid touching hot muffler or engine components.
12. Disengage power to attachments when transporting or not in use.
13. Take all possible precautions when leaving the vehicle unattended. Disengage the power take-off, lower the attachments, shift into neutral, set the parking brake, stop the engine, and remove the key.
14. Do not stop or start suddenly when going uphill or downhill. Mow up and down the face of slopes (not greater than 15°), never across the face. Refer to page 51.
15. Reduce speed on slopes and make turns gradually to prevent tipping or loss of control. Exercise extreme caution when changing direction on slopes.
16. While going up or down slopes, place gear shift control lever in 1st gear position to negotiate the slope without stopping.
17. Never mow in wet or slippery grass, when traction is unsure, or at a speed which could cause a skid.
18. Stay alert for holes in the terrain and other hidden hazards. Keep away from drop-offs.
19. Do not drive too close to creeks, ditches, and public highways.
20. Exercise special care when mowing around fixed objects in order to prevent the blades from striking them. Never deliberately run tractor or mower into or over any foreign objects.
21. Never shift gears until tractor comes to a stop.
22. Never place hands or feet under the mower, in discharge chute, or near any moving parts while tractor or mower is running. Always keep clear of discharge chute.
23. Use care when pulling loads or using heavy equipment.
 - a. Use only approved drawbar hitch points.
 - b. Limit loads to those you can safely control.
 - c. Do not turn sharply. Use care when backing.
 - d. Use counterweight or wheel weights when suggested in owner's manual.
24. Watch out for traffic when crossing or near roadways.
25. When using any attachments, never direct discharge of material toward bystanders nor allow anyone near the vehicle while in operation.
26. Handle gasoline with care - it is highly flammable.
 - a. Use approved gasoline containers.
 - b. Never remove the fuel cap of the fuel tank or add gasoline to a running or hot engine or an engine that has not been allowed to cool for several minutes after running. Never fill tank indoors. Always clean up spilled gasoline.
 - c. Open doors if the engine is run in the garage - exhaust fumes are dangerous. Do not run the engine indoors.
27. Keep the vehicle and attachments in good operating condition, and keep safety devices in place and working.
28. Keep all nuts, bolts, and screws tight to be sure the equipment is in safe working condition.
29. Never store the equipment with gasoline in the tank inside a building where fumes may reach an open flame or spark. Allow the engine to cool before storing in any enclosure.
30. To reduce fire hazard, keep the engine free of grass, leaves, or excessive grease. Do not clean product while engine is running.
31. Except for adjustments, DO NOT operate engine if air cleaner or cover directly over carburetor air intake is removed. Removal of such part could create a fire hazard.
32. Do not operate without a muffler, or tamper with exhaust system. Damaged mufflers or spark arresters could create a fire hazard. Inspect periodically and replace if necessary.
33. The vehicle and attachments should be stopped and inspected for damage after striking a foreign object, and the damage should be repaired before restarting and operating the equipment.
34. Do not change the engine governor settings or overspeed the engine; severe damage or injury may result.
35. When using the vehicle with mower, proceed as follows:
 - a. Mow only in daylight or in good artificial light.
 - b. Shut the engine off when unclogging chute.
 - c. Check the blade mounting bolts for proper tightness at frequent intervals.
36. Do not operate the mower without the entire grass catcher, on mowers so equipped, or the deflector shield in place.
37. Disengage power to mower before backing up. Do not mow in reverse unless absolutely necessary and then only after careful observation of the entire area behind the mower.
38. Under normal usage the grass catcher bag material is subject to deterioration and wear. It should be checked frequently for bag replacement. Replacement bags should be checked to ensure compliance with the original manufacturer's recommendations or specifications.

CONGRATULATIONS on your purchase of a Sears Garden Tractor. It has been designed, engineered and manufactured to give you the best possible dependability and performance. Should you experience any problem you cannot easily remedy, please contact your nearest Sears Service Department. We have competent, well-trained technicians and the proper tools to service or repair this unit.

MAINTENANCE AGREEMENT

A Sears Maintenance Agreement is available on this product. See the nearest Sears store or service center for details.

CUSTOMER RESPONSIBILITIES

Read and retain this manual. Study and observe the safety rules. Always use care when using your tractor. Always keep your tractor and mower clean. Follow a regular schedule in maintaining, caring for, and using your tractor. A well cared for tractor will run better and last longer.

ATTACHMENTS

This unit can use many attachments now available at your Sears store. It can use attachments that engage the ground like a plow, harrow, cultivator, or tiller. See pages 48-49 for a list of available attachments.

SERIAL
NUMBER _____

DATE OF PURCHASE _____

THE SERIAL NUMBER WILL BE FOUND ON THE MODEL PLATE UNDER THE SEAT.

YOU SHOULD RECORD THESE NUMBERS AND KEEP FOR FUTURE REFERENCE.

LIMITED TWO YEAR WARRANTY ON ELECTRIC START RIDING EQUIPMENT

For two years from date of purchase, when this riding equipment is maintained, lubricated, and tuned up according to the operating and maintenance instruction in the owner's manual, Sears will repair free of charge any defect in material or workmanship in this electric start riding equipment.

This warranty excludes blade(s), blade adapter(s), spark plug(s), air cleaner and belt(s), which are expendable and become worn during normal use.

This warranty does not cover:

- Tire replacement or repair caused by punctures from outside objects (such as nails, thorns, stumps, or glass); and
- repairs necessary because of operator abuse or negligence, including the failure to maintain the equipment according to instructions contained in the owner's manual; and
- riding equipment used for commercial or rental purposes.

FULL 90 DAY WARRANTY ON BATTERY

For 90 days from the date of purchase, if any battery included with this riding equipment proves defective in material or workmanship and our testing determines the battery will not hold a charge, Sears will replace the battery at no charge.

WARRANTY SERVICE IS AVAILABLE BY CONTACTING THE NEAREST SEARS SERVICE CENTER DEPARTMENT IN THE UNITED STATES. This warranty applies only while this product is in use in the United States.

This warranty gives you specific legal rights, and you may also have other rights which may vary from state to state.

SEARS, ROEBUCK and CO., D/731CR-W, Sears Tower, Chicago, IL 60684



DO NOT OVERLOAD TRACTOR OR
TOW WEIGHTS GREATER THAN 150
POUNDS (68 KG).

INDEX

A

Adjustments:	
Brake	16
Carburetor	20
Mower	
Front-To-Rear	22
Side-To-Side	21
Height	21
Throttle Control Cable	20
Shifter Shaft	25
Air Cleaner	17
Air Screen, Engine	18
Assembly	5-10
Attachments	48-49

B

Battery:	
Charging	7, 20
Cleaning	17
Installation	8
Levels	7
Preparation	7
Starting with Weak Battery	20
Storage	25
Terminals	17

Belt:	
Motion Drive	
Removal/Replacement	24
Mower Drive	
Installation	10
Removal	22
Mower Blade Drive	
Removal/Replacement	23

Blade:	
Sharpening	16
Replacement	24
Brake Adjustment	16

C

Carburetor Adjustment	20
Controls, Tractor	11
Cutting Level, Mower	10

E

Engine:	
Air Cleaner	17
Air Screen	18
Cooling fins	18
Oil Change	17
Oil Level	15
Oil Type	15
Repair Parts	44-49
Starting	12
Storage	25

F

Filter:	
Air Cleaner	17
Fuel	18
Fuel:	
Type	12
Storage	25
Fuse	21

H

Hood Removal/Installation	21
---------------------------------	----

L

Leveling Mower Deck	21-22
Lubrication:	
Chart	19
Tractor Pivot Points	18

M

Maintenance	15
Air Cleaner	17
Foam Pre-cleaner	17
Air Screen, Engine	18
Battery	17
Blade Sharpening	16
Brake Adjustment	16
Engine Oil	15
Fuel Filter	18
Lubrication Chart	19
Spark Plugs	18
Tire Care	16, 24

Mower:	
Adjustment, Front-to-Rear	22
Adjustment, Side-to-Side	21
Height	21
Blade Sharpening	16
Blade Replacement	24
Cutting Level	10
Installation	10
Operation	13
Removal	22
Mowing Tips	14
Muffler	18
Spark Arrester	2,32

O

Oil:	
Cold Weather Conditions	15
Engine	15
Storage	25
Operation	11-14
Operating Your Mower	13
Operating Your Tractor	13
Starting the Engine	12
Stopping Your Tractor	12

Tractor Operation on Hills	14
Options:	
Spark Arrester	2, 32
Attachments	48-49

P

Parking Brake	11
Parts Bag	5-6
Parts, Replacement/Repair	30-49

R

Repair and Adjustments	19-25
Blade	24
Carburetor	20
Fuse	21
Hood Removal/Installation	21
Motion Drive Belt	
Removal/Replacement	24
Mower Drive Belt	
Installation	10
Removal	22
Mower Blade Drive Belt	
Removal/Replacement	23
Mower Adjustment	
Front-to-Rear	22
Side-to-Side	21
Height	21
Mower Removal	23
Tire Care	16, 24
Repair Parts	30-49

S

Safety Rules	2
Seat	7
Service Record	27
Slope Guide Sheet	51
Spark Plugs	18
Speed Control Chart	13
Starting the Engine	12
Steering Wheel	8
Stopping the Tractor	12
Storage	25

T

Throttle Control Cable	
Adjustment	20
Tires	16, 24
Trouble Shooting Chart	26-27
Transaxle:	
Repair Parts	42-43
Shifter Adjustment	25

W

Warranty	3
Wiring Schematic	29

ASSEMBLY

KNOW YOUR TRACTOR

READ THIS OWNER'S MANUAL BEFORE OPERATING YOUR GARDEN TRACTOR. If you understand the machine and its operation, you will achieve efficient and peak performance. While reading the manual, compare the illustrations with your Garden Tractor to familiarize yourself with the location of various controls and adjustments. Study the operating instructions and safety precautions thoroughly to insure proper functioning of your Garden Tractor and to prevent injury to yourself and others. Be sure to pay strict attention to all notes and cautions; they are included for your safety. Save this manual for future reference.

UNPACKING INSTRUCTIONS

1. Remove box from carton. The box contains the items shown below.
2. Cut down four corners of the carton with a utility knife and fold down sides.
3. Remove mower deck from skid.
4. Disengage Parking Brake.
5. Carefully guide the tractor backwards off the skid.



The operation of any tractor can result in foreign objects thrown into the eyes, which can result in severe eye damage. Always wear safety glasses or eye shields before starting your tractor and while mowing. We recommend Wide Vision Safety Mask for over the spectacles or standard safety glasses, available at Sears Retail or Catalog Stores.

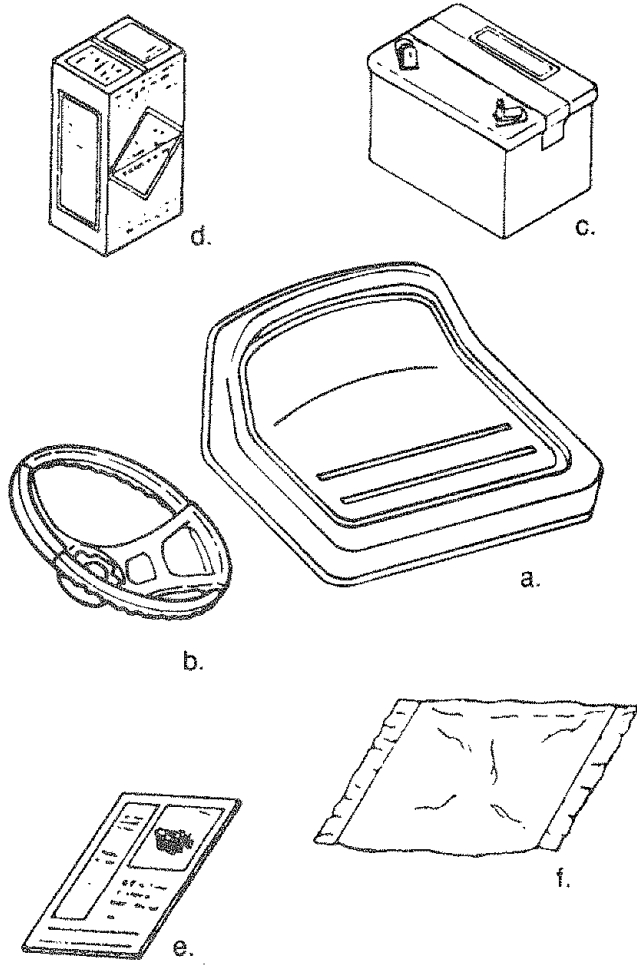

a. Seat	d. Battery Acid
b. Steering Wheel	e. Owner's Manual
c. Battery	f. Parts Bag

Parts Bag Contents Not Shown Full Size



(2) Battery Carriage Bolts - 1/4 - 20 x 7 1/2



Terminal Guard

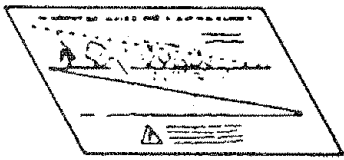

15° Slope Instruction Sheet

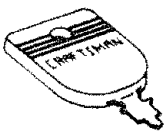

(2) Keys

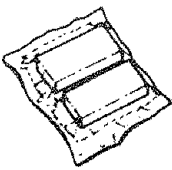



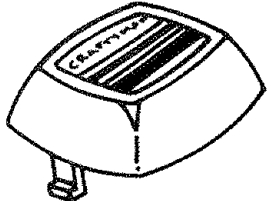

(6) Battery Caps



Steering Wheel Insert

ASSEMBLY

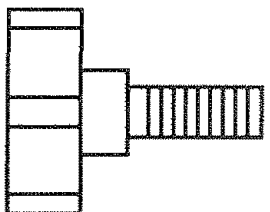
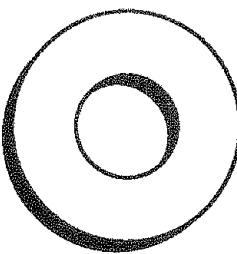
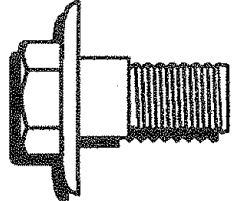
ASSEMBLY LOCATION	PARTS BAG CONTENTS SHOWN FULL SIZE
BATTERY	 <p>(2) Wing Nut, 1/4 - 20</p>
BATTERY TERMINALS	 <p>(2) Hex Bolt, 1/4 - 20 x 3/4</p>  <p>(2) Lockwasher, 1/4</p>  <p>(2) Washer, 9/32 x 5/8 x 16 Ga.</p>  <p>(2) Hex Nut, 1/4 - 20</p>
SEAT	 <p>(1) Adjustment Knob 1/2 - 13 x 1</p>  <p>(1) Washer 17/32 x 1 3/16 x 12 Ga.</p>  <p>(1) Shoulder Bolt 5/16 - 18</p>

ASSEMBLY

To assemble and adjust your tractor you will need:

- (2) 7/16" Wrenches Ratchet wrench
- (1) 3/4" Wrench Tire Pressure Gauge
- (1) 9/16" Wrench Screwdriver
- (1) 1/2" Wrench Utility Knife
- (1) 3/4" Socket

NOTE: RIGHT HAND (R.H.) AND LEFT HAND (L.H.) ARE DETERMINED FROM OPERATOR'S POSITION WHILE SEATED ON THE TRACTOR.



WEAR EYE AND FACE SHIELD.
WASH HANDS OR CLOTHING IMMEDIATELY IF ACCIDENTALLY IN CONTACT WITH BATTERY ACID.
DO NOT SMOKE, FUMES FROM CHARGED BATTERY ACID ARE EXPLOSIVE.

NOTE: THIS TRACTOR IS EQUIPPED WITH AN OPERATOR PRESENCE SENSING SWITCH. ANY ATTEMPT BY THE OPERATOR TO LEAVE THE SEAT WITH THE ENGINE RUNNING AND ATTACHMENT CLUTCH ENGAGED WILL SHUT OFF THE ENGINE.

1. Prepare Battery

READ INSTRUCTIONS INCLUDED WITH THE BATTERY VENT CAPS FOUND IN BAG OF PARTS. ALWAYS WEAR GLOVES, CLOTHING AND GOGGLES TO PROTECT YOUR HANDS, SKIN AND EYES.

- a. Fill and charge battery (before installing). NOTE: SEE DETAILED INSTRUCTIONS PACKAGED WITH BATTERY VENT CAPS IN BAG OF PARTS.

NOTE: OVERCHARGING WILL SHORTEN BATTERY LIFE.

- b. Fill battery with battery acid to bottoms of tubes in cells (Fig 1). DO NOT OVERFILL. OVERFILLING WILL RESULT IN DAMAGE TO TRACTOR.
- c. Check level of battery acid after 30 minutes. Add additional battery acid if necessary. NOTE: PRESS VENT CAPS INTO BATTERY UNTIL FASTENED SECURELY.

NOTE: OBSERVE SAFETY PRECAUTIONS, LISTED IN BOX ABOVE, REQUIRED FOR BATTERY CHARGING.

- d. Charge battery at a rate of six amperes for one hour.
- e. Neutralize excess battery acid (from filling battery) for disposal by adding it to 9 litres (2 gallons) of water in a 23 litre (5 gallon) plastic container. Stir with a wooden or plastic paddle while adding baking soda until the addition of more soda causes no more foaming.

2. Install Seat

Seat position should be adjusted forward or backward so that the operator can comfortably reach Clutch/Brake Pedal and safely operate the tractor (Fig. 2).

- a. Remove cardboard from seat pan.
- b. Place seat on seat pan. Screw adjustment knob and flat washer into seat (Fig. 3). Screw shoulder bolt into seat (Fig. 3). Adjustment knob, shoulder bolt and washers found in bag of parts (shown full size on page 6).

CUT AWAY VIEW

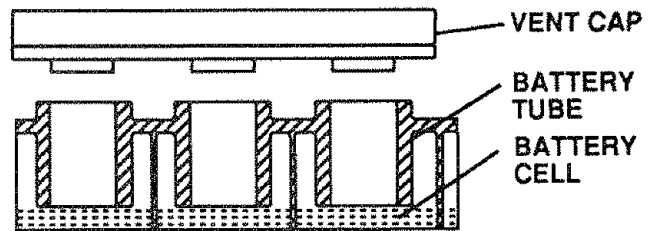

FIGURE 1

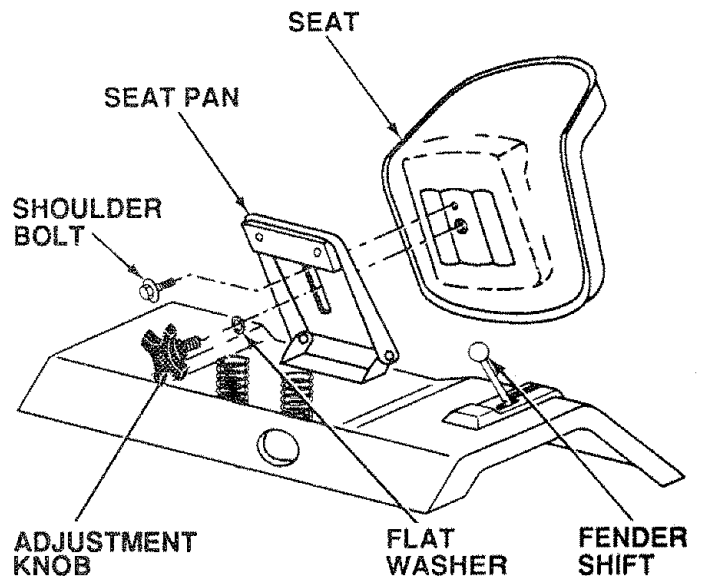

FIGURE 2



THE ADJUSTMENT KNOB MUST BE TIGHTENED SECURELY TO PREVENT MOVEMENT OF SEAT.

- c. Tighten shoulder bolt using a 1/2" wrench. NOTE: THE SHOULDER BOLT WILL BE LOOSE IN THE SEAT PAN SLOT.
- d. Tighten adjustment knob finger tight.
- e. Place seat in operating position. Sit on the seat and press clutch/brake pedal all the way down. If operating position is not comfortable, adjust seat.
- f. To adjust: raise seat. Loosen adjustment knob. Slide seat to desired position. Tighten adjustment knob securely.

ASSEMBLY

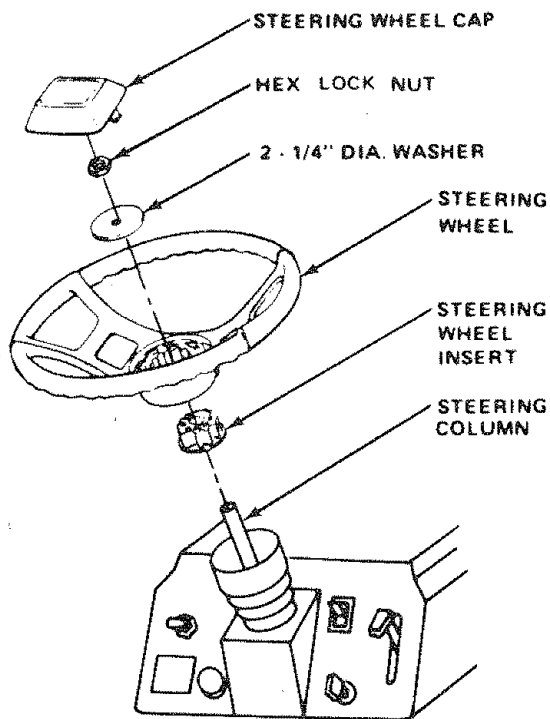
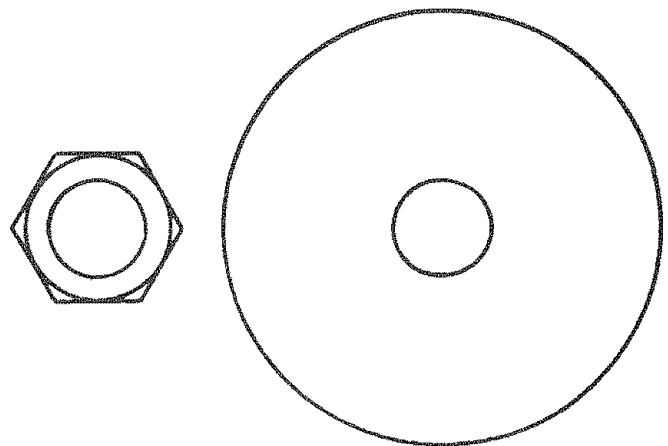

FIGURE 3

3. Install Steering Wheel

NOTE: POSITION FRONT WHEEL FORWARD.

a. Use a 3/4" wrench to remove lock nut, and 2 - 1/4" diameter washer (shown full size below) from steering column (Fig. 3).



- b. Position steering wheel over steering wheel insert (Fig. 3). BARS OF STEERING WHEEL SHOULD POINT STRAIGHT ACROSS TRACTOR.
- c. Secure steering wheel to steering column using 2-1/4" diameter washer and lock nut (Fig. 3). Torque to 68 N-m (50 Ft. Lbs.)
- d. Snap steering wheel cap in place on steering wheel. Steering wheel cap found in bag of parts.

4. Check Tires

Reduce tire pressure to 1 Kg/cm² (14 PSI) in front tires and 0.71 Kg/cm² (10 PSI) in rear tires. (Tires were overinflated for shipping purposes.)

5. Install Battery

DO NOT SHORT BATTERY TERMINALS



BEFORE INSTALLING BATTERY, REMOVE METAL BRACLETS, WRISTWATCH BANDS, RINGS, ETC.



IF BATTERY IS REMOVED, DO NOT OPERATE ENGINE. SPARKING MAY OCCUR.

- a. Lift hood from rear sides (Fig. 4).
- b. Lift out air intake duct.
- c. Make sure drain tube (Fig. 5) is fastened to drain hole in battery tray and battery tray is positioned in hole of battery support.
- d. Place battery in plastic tray (battery terminals to front of tractor) (Fig. 5).

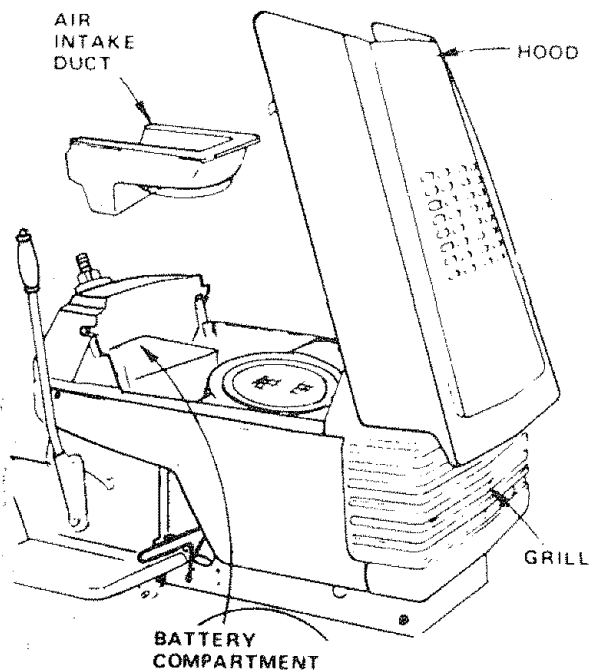

FIGURE 4



POSITIVE TERMINAL MUST BE CONNECTED FIRST TO PREVENT SPARKS FROM ACCIDENTAL GROUNDING.

ASSEMBLY

- e. Connect RED battery cable to positive (+) battery terminal with hex bolt, flat washer, lockwasher and hex nut (shown full size below) found in bag of parts (Fig. 5). Tighten securely.
- f. Connect BLACK ground cable to negative (-) battery terminal with remaining hex bolt, flat washer, lockwasher and hex nut (shown full size below) found in bag of parts (Fig. 5). Tighten securely.



NOTE: IF YOU HAVE A WEAK BATTERY, SEE "STARTING YOUR TRACTOR WITH A WEAK BATTERY" (PAGE 20).

- g. Using the square hole on one side of the battery support (Fig. 6) insert one battery bolt, head of bolt facing down. Fasten the battery bolt to the terminal guard using wing nut as shown (Fig. 6). Bolts, nuts, and terminal guard, shown below, are found in bag of parts.
- h. Assemble the remaining battery bolt to other side of battery support and fasten terminal guard to it with remaining wing nut. Tighten both wing nuts securely (by hand) at the same time (Fig. 6).

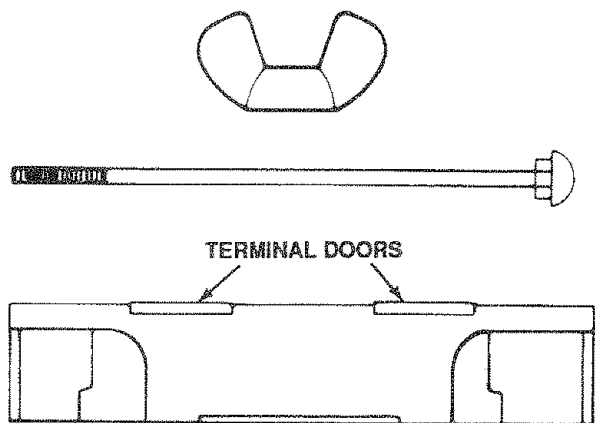

- i. Replace air intake duct (Fig. 4). Make sure bottom lip of duct sits between battery and lip of battery tray.
- j. Remove plastic from tractor hood and close.

NOTE: USE TERMINAL ACCESS DOORS (FIG. 6) FOR:

1. INSPECTION FOR SECURE CONNECTIONS (TIGHTEN HARDWARE)
2. INSPECTION FOR CORROSION
3. TESTING BATTERY
4. JUMPING (IF REQUIRED)
5. CHARGING (IF REQUIRED)

KEEP TERMINAL ACCESS DOORS CLOSED WHEN NOT IN USE.



DO NOT START ENGINE UNTIL MOWER SUSPENSION BRACKET HAS BEEN RELEASED. SEE MOWER AND DRIVE BELT INSTALLATION, PAGE 10.

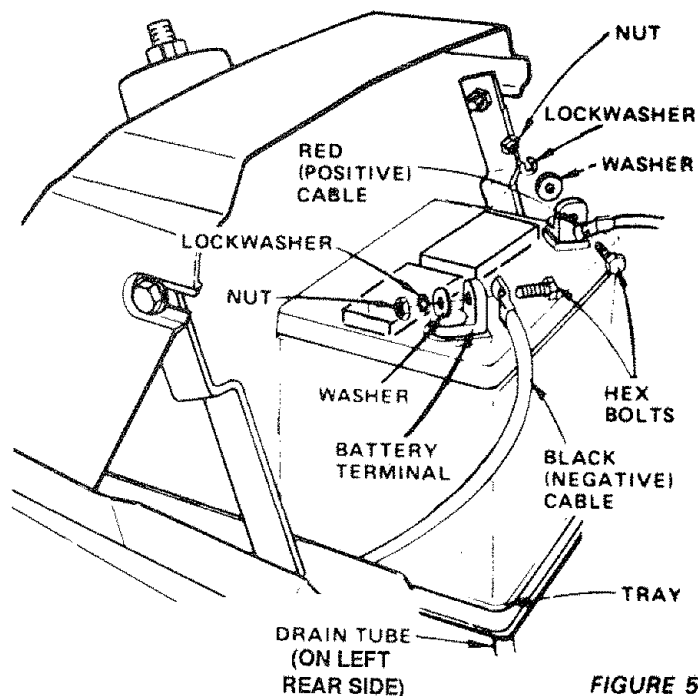

FIGURE 5

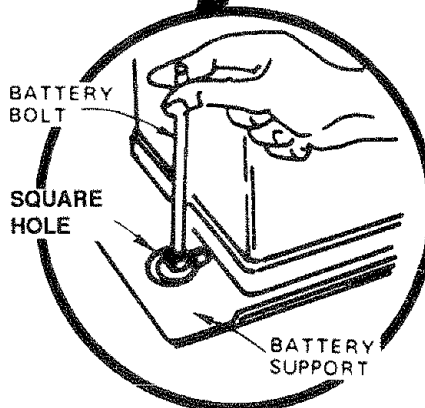
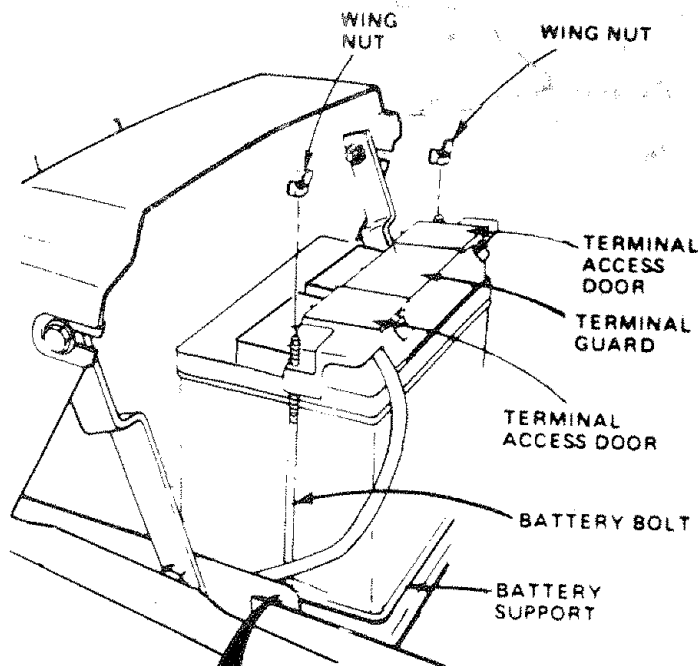

FIGURE 6

ASSEMBLY

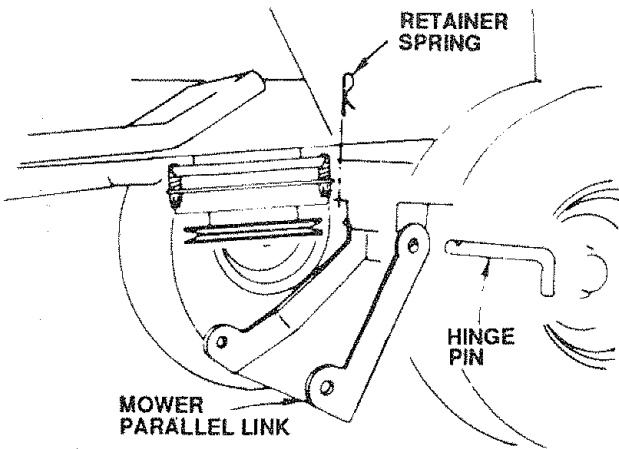

FIGURE 7

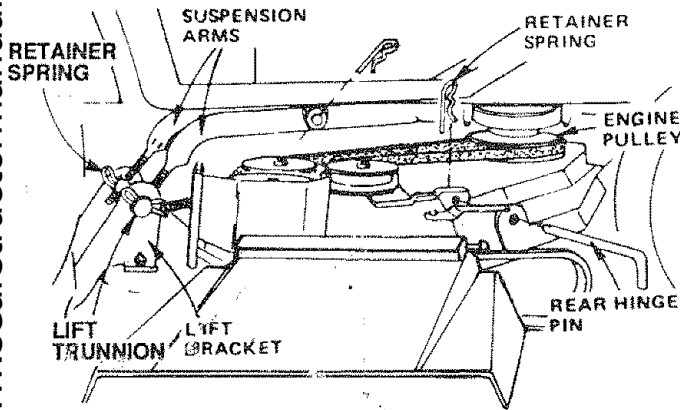

FIGURE 8

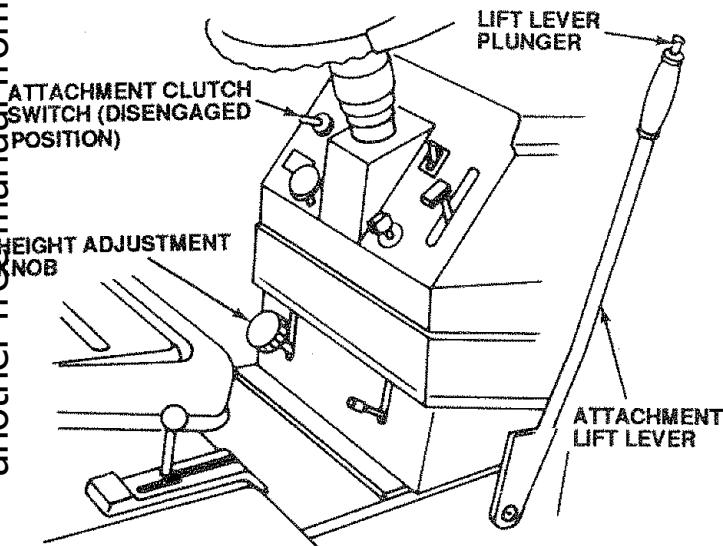

FIGURE 9

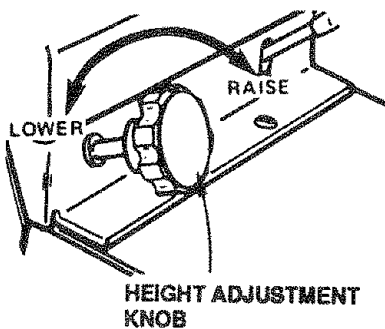

FIGURE 10

6. Mower and Drive Belt Installation

INSTALL MOWER PARALLEL LINK

Your tractor has been shipped with the mower parallel link included in the parts carton. Install mower parallel link on tractor (Fig. 7) using hinge pin and retainers spring.

NOTE: SMALLER END OF PARALLEL LINK MOUNTS TO TRACTOR. USE THE SHORTEST HINGE PIN FOR MOUNTING.

INSTALL MOWER

Your mower installs without the use of tools.

- Raise attachment lift lever (Fig. 9) to its highest position.
- Turn height adjustment knob counterclockwise (↺) to lowest position (Fig. 10)
- Slide mower under tractor with discharge guard to R.H. side.
- Install rear hinge pin through mower lift brackets and parallel link (Fig. 8). Secure with retainers spring.
- Move attachment lift lever (Fig. 9) forward to lower suspension arms. Remove retainers springs from lift trunnions (Fig. 8).
- Slide trunnions through upper lift bracket holes and secure with retainers springs (Fig. 8).
- Pull L.H. idler pulley (Fig. 12) toward the right hand side of the tractor and roll belt over engine pulley (Fig. 8).

NOTE: MOWER DRIVE BELT INSTALLATION DECAL LOCATED ON MOWER HOUSING.

- Use attachment lift lever (Fig 9) to raise mower.
- Turn height adjustment knob clockwise (↻) to the middle of its travel (Fig. 10).

7. Check Cutting Level

The blade housing was set at the factory to cut level. After mowing a short distance, look at the area that was cut. If the blade housing cuts uneven, see "MOWER ADJUSTMENT," page 21

8. Final Assembly

- Make sure all fasteners are tight.
- Read and follow the operation instructions (page 11). Know the location and purpose of all controls.
- Check oil and gasoline (page 12) before starting the tractor.

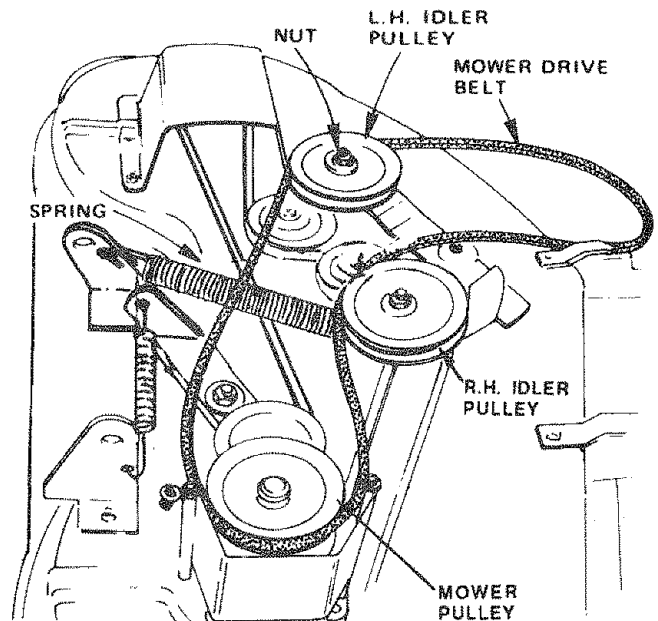
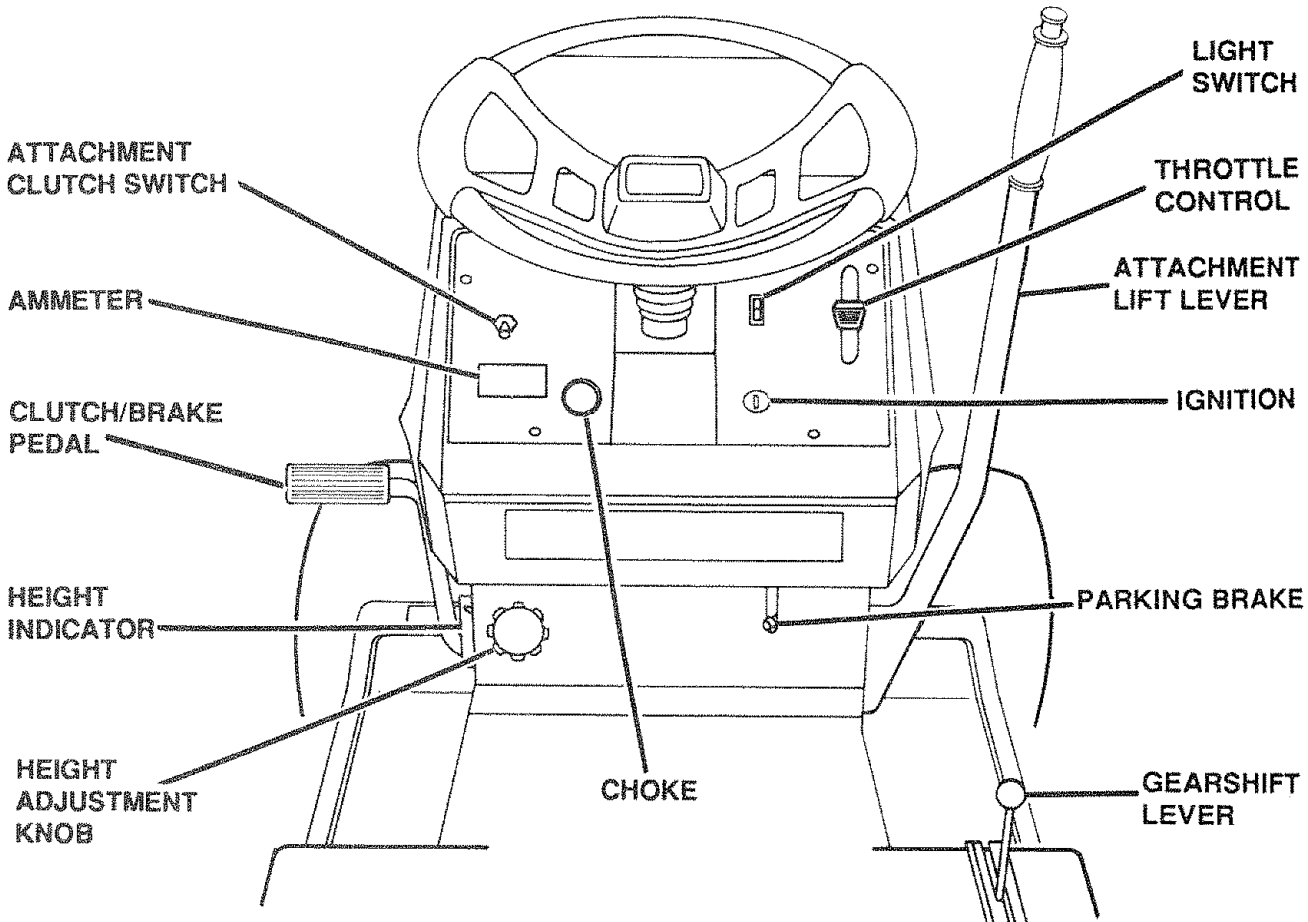

FIGURE 11

OPERATION

READ THIS OWNER'S MANUAL BEFORE OPERATING YOUR GARDEN TRACTOR. If you understand the unit and its operation, you will achieve efficient and peak performance. While reading the manual, compare the illustrations with your Garden Tractor to familiarize yourself with the location of the various controls and adjustments. Study the operating instructions and safety precautions thoroughly to insure proper functioning of your Garden Tractor and to prevent injury to yourself and others. Be sure to pay strict attention to all warnings and cautions; they are included for your safety. Save this manual for future reference.



another free manual from www.searstractormanuals.com

AMMETER: Each time you start your tractor, check your ammeter. The needle should move toward the () charging mark indicating the battery is being recharged as you operate your tractor. The headlights will not show a discharge on the ammeter because they are not connected to the battery. (They have their own electrical source.)

ATTACHMENT CLUTCH SWITCH: Pull switch out and up to engage attachment. There will be an engine hesitation as the clutch engages.

ATTACHMENT LIFT LEVER: Use the attachment lift lever to raise and lower the attachment mounted to your tractor. Move the lift lever forward to lower attachment.

CLUTCH/BRAKE PEDAL: The pedal has 2 functions; a clutch and a brake. To engage the brake push the pedal completely down.

HEIGHT ADJUSTMENT KNOB: Use the height adjustment knob to adjust the mower height. With the attachment lift lever in the "up" position, turn knob clockwise () to raise cutting height and counter-clockwise () to lower mower cutting height. Lower attachment lift lever.

HEIGHT INDICATOR: Indicates height setting of mower deck. Controlled by height adjustment knob.

GEARSHIFT: Press the clutch/brake pedal down firmly and move gearshift lever to desired speed.

IGNITION: Place key in ignition and turn to the right to start.

LIGHT SWITCH: Turns the headlights on and off.

PARKING BRAKE: To set the parking brake, push the clutch/brake pedal completely down. Hold the parking brake lever in "Engaged" position and release pressure from pedal. Clutch/brake pedal will remain in brake position. To release, push pedal in.

THROTTLE CONTROL: Use the throttle control to increase or decrease the speed of the engine.

CHOKE: To start a cold engine, pull choke out to engage.

OPERATION

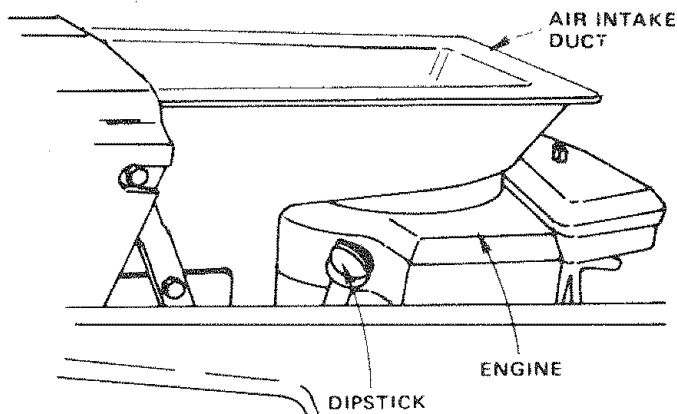

FIGURE 12

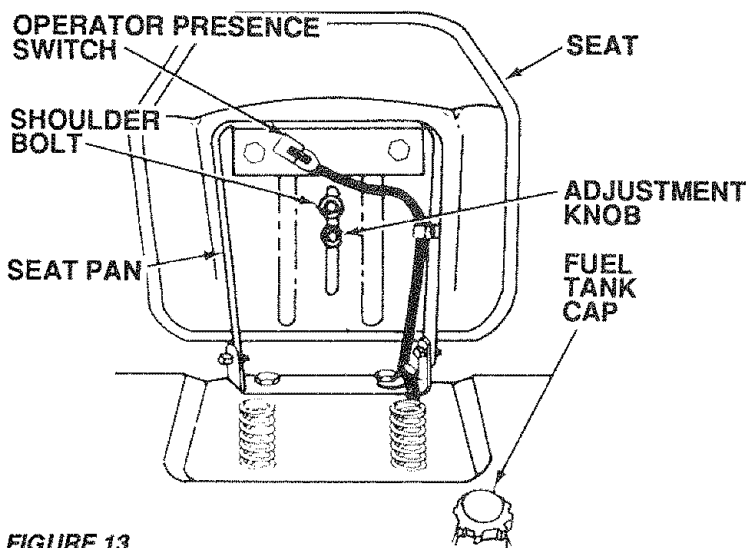

FIGURE 13

1. Stopping Your Tractor



KNOW HOW TO STOP YOUR TRACTOR BEFORE YOU ATTEMPT TO START THE ENGINE.

NOTE: REMOVE KEY WHEN LEAVING TRACTOR TO PREVENT UNAUTHORIZED USE:

- Push clutch/brake pedal into full "BRAKE" position (Fig. 14).
- Move gear shift lever to "NEUTRAL" position (Fig. 15).
- Place parking brake in "ENGAGED" position and release pressure from clutch/brake. Pedal should remain in "BRAKE" position (Fig. 14).

NOTE: MAKE SURE PARKING BRAKE WILL HOLD TRACTOR SECURE.

- Place attachment clutch switch in "DISENGAGED" position (Fig. 15).
- Move throttle control to "S" (slow) position (Fig. 15).
- Turn ignition key to "OFF" position (Fig. 15).

NOTE: NEVER USE CHOKE TO STOP ENGINE.

2. Starting the Engine



LEARN TO START, STOP AND REVERSE YOUR TRACTOR IN A LARGE, OPEN AREA.



THIS TRACTOR IS EQUIPPED WITH INTERLOCK SWITCHES TO PREVENT STARTING OF THE TRACTOR ENGINE WHILE THE ATTACHMENT CLUTCH SWITCH IS IN THE "ENGAGED" POSITION AND/OR THE FOOT PEDAL IS NOT FULLY DEPRESSED. IMMEDIATELY REPLACE SWITCHES THAT ARE NOT IN PROPER WORKING ORDER. DO NOT ATTEMPT TO DEFEAT THE PURPOSE OF THESE SWITCHES.

- This engine has been shipped filled with summer weight oil (For cold weather operation see chart page 15). Check engine oil level. See page 15.
- Fill fuel tank (Fig. 13). Use fresh, clean, regular unleaded gasoline. (Use of leaded gasoline will increase carbon and lead oxide deposits and reduce valve life.) Capacity is 13 litres (3-1/2 gallons).

NOTE: FRESH, CLEAN WINTER GRADE FUEL MUST BE USED TO INSURE GOOD COLD WEATHER STARTING.

CAUTION: EXPERIENCE INDICATES THAT ALCOHOL BLENDED FUELS (CALLED GASOHOL OR USING ETHANOL OR METHANOL) CAN ATTRACT MOISTURE WHICH LEADS TO SEPARATION AND FORMATION OF ACIDS DURING STORAGE. ACIDIC GAS CAN DAMAGE THE FUEL SYSTEM OF ANY ENGINE WHILE IN STORAGE.

TO AVOID ENGINE PROBLEMS, THE FUEL SYSTEM SHOULD BE EMPTIED BEFORE STORAGE FOR 30 DAYS OR LONGER. DRAIN THE GAS TANK, START THE ENGINE AND LET IT RUN UNTIL THE FUEL LINES AND CARBURETOR ARE EMPTY. USE FRESH FUEL NEXT SEASON. SEE STORAGE INSTRUCTIONS FOR ADDITIONAL INFORMATION.

NEVER USE ENGINE OR CARBURETOR CLEANER PRODUCTS IN THE FUEL TANK OR PERMANENT DAMAGE MAY OCCUR.



FILL TO BOTTOM OF GAS TANK FILLER NECK. DO NOT OVERFILL. WIPE OFF ANY SPILLED OIL OR FUEL. DO NOT STORE, SPILL OR USE GASOLINE NEAR AN OPEN FLAME.

- Place attachment clutch switch in "disengaged" position (Fig. 15).
- Push clutch/brake pedal fully into brake position.
- Place gear shift lever in "NEUTRAL" position (Fig. 15).
- Pull choke out (Fig. 15).
- Move throttle control to middle position (Fig. 15).
- Turn ignition key clockwise (↻) to "START" position and release key as soon as engine starts. NOTE: DO NOT RUN STARTER CONTINUOUSLY FOR MORE THAN FIFTEEN SECONDS PER MINUTE. If engine does not start after several attempts, move throttle control to "F" (fast) position, wait a few minutes and try again.

NOTE: IF YOU HAVE A WEAK BATTERY, SEE "STARTING YOUR TRACTOR WITH A WEAK BATTERY" (Page 20).

- After engine is warm, push choke in. The first time you start the engine, it will take extra cranking time to move fuel from tank to the engine.

OPERATION

NOTE: ALLOW ENGINE TO WARM UP FOR A FEW MINUTES BEFORE ENGAGING CLUTCH OF TRACTOR OR ATTACHMENT.

When restarting a warm engine, move throttle control midway between "S" (slow) and "F" (fast) positions. Choke may not have to be used.

IMPORTANT: BEFORE DRIVING THE TRACTOR, INSTALL MOWER OR REMOVE MOWER PARALLEL LINK.

SPEED SELECTION GUIDE

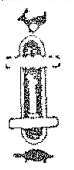
FUNCTION	GEARSHIFT	THROTTLE
Normal Mowing	2 or 3	
Heavy Mowing	1 or 2	
Snow Removal	1	FAST
Tilling Plowing	1	MID THROTTLE
Dozing	1	
Grading	2	
Transport	3-6	SLOW-FAST

3. Operating Your Tractor and Mower

NOTE: THIS TRACTOR IS EQUIPPED WITH AN OPERATOR PRESENCE SENSING SWITCH. ANY ATTEMPT BY THE OPERATOR TO LEAVE THE SEAT WITH THE ENGINE RUNNING AND THE ATTACHMENT CLUTCH SWITCH ENGAGED WILL SHUT OFF THE ENGINE.

CAUTION TO AVOID INJURY

1. Read owner's manual.
2. Know the location and function of all controls.
3. Keep guards, safety shields and switches in place and working.
4. Remove objects that can be thrown by blades.
5. Do not mow when children and others are around.
6. Never carry children or passengers.
7. Always look behind machine before backing.
8. Do not mow where machine can tip or slip.
9. If machine stops going uphill, stop blade and back slowly down.
10. Be sure blades and engine have stopped before placing hands or feet near the blades.
11. Remove key when leaving machine.

MAKE SURE PARKING BRAKE WILL HOLD TRACTOR SECURE.



NEVER PLACE YOUR HANDS OR FEET IN OR UNDER ANY POWERED ATTACHMENT OR NEAR ANY MOVING PART WHILE TRACTOR OR ANY POWERED ATTACHMENT IS RUNNING.

NOTE: ALWAYS OPERATE ENGINE AT FULL THROTTLE WHEN MOWING TO ASSURE BETTER MOWING PERFORMANCE AND PROPER DISCHARGE OF CUT MATERIAL. REGULATE GROUND SPEED BY SELECTING A LOW ENOUGH GEAR (TABLE 1) TO GIVE THE MOWER CUTTING PERFORMANCE PLUS QUALITY OF CUT DESIRED.

DO NOT OPERATE THE MOWER WITHOUT EITHER THE ENTIRE GRASS CATCHER, ON MOWERS SO EQUIPPED, OR THE DEFLECTOR SHIELD IN PLACE.



- a. Select desired height of cut position using height adjustment knob (Fig. 15).
- b. Raise lift lever and place attachment clutch switch in disengaged position.
- c. Push clutch/brake pedal down firmly (Fig. 14).
- d. Start engine (page 12).
- e. With engine running and warm place throttle control midway between "S" (slow) and "F" (fast) position.
- f. Engage mower with the attachment clutch switch
- g. Move gear shift lever to desired gear.
- h. Lower mower into cutting position using attachment lift lever.
- i. Release clutch/brake pedal to start movement (Fig. 14).
- j. Move throttle control to "F" (Fast) position.

NOTE: SELECT A GROUND SPEED THAT WILL SUIT THE TERRAIN, QUALITY OF CUT AND ATTACHMENT BEING USED (TABLE 1).

another free manual from www.searctractormanuals.com

TABLE 1

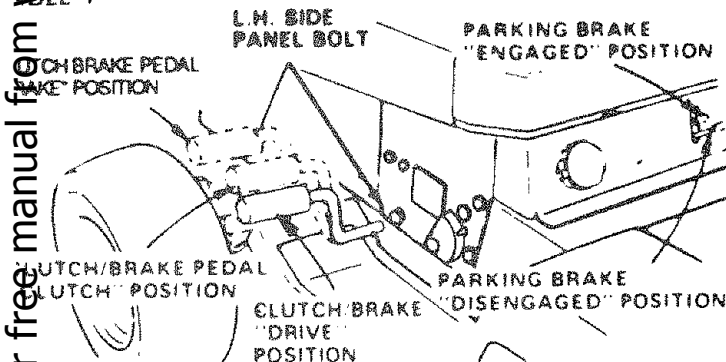

FIGURE 14



READ THE "RULES FOR SAFE OPERATION" CAREFULLY BEFORE OPERATING YOUR MOWER.

THE MOWER MUST BE ADJUSTED PROPERLY FROM FRONT TO REAR AND LEVELED FROM SIDE TO SIDE BEFORE OPERATING. THIS IS NECESSARY FOR LEVEL AND EFFICIENT MOWING. REFER TO PAGE 21.

CAUTION: DO NOT ADD ADDITIONAL WEIGHT TO THE TRACTOR OTHER THAN THE OPTIONAL WHEEL WEIGHTS. EXCESSIVE WEIGHT MAY OVERLOAD AND DAMAGE THE TRANSMISSION.



DO NOT OVERLOAD TRACTOR OR TOW WEIGHTS GREATER THAN 68 KG (150 POUNDS).

OPERATION

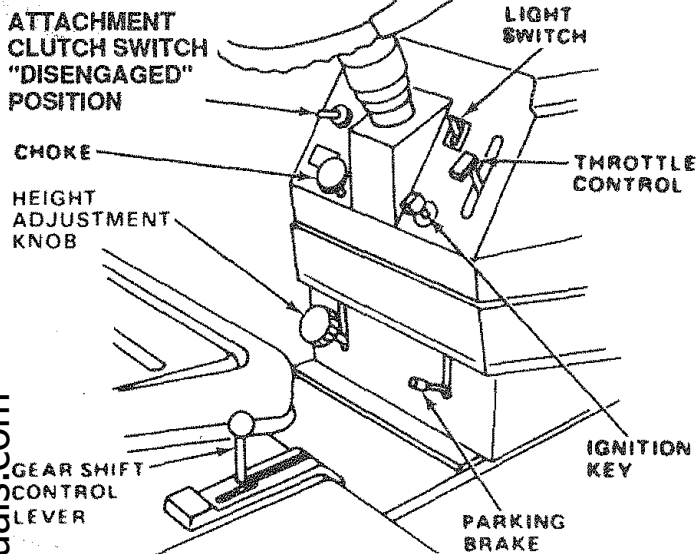

FIGURE 15

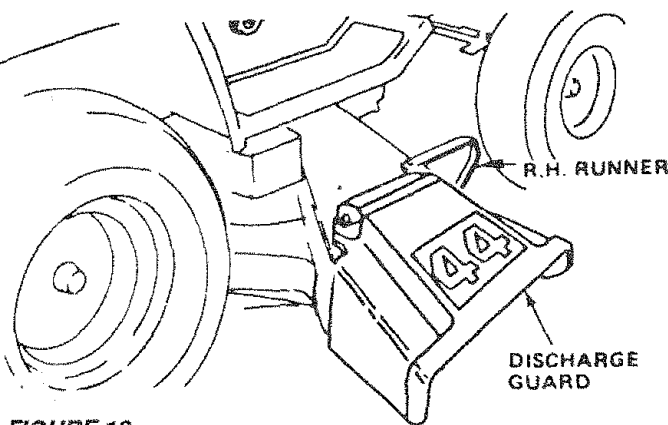

FIGURE 16

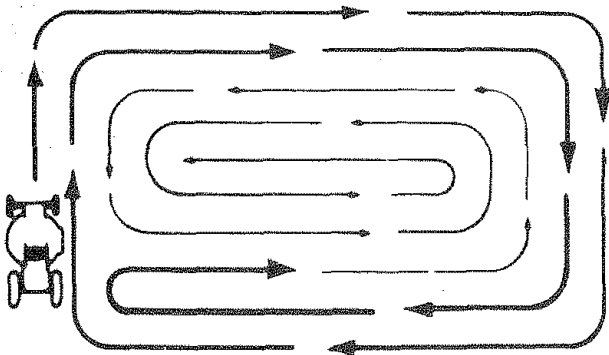

FIGURE 17

CAUTION: NEVER RUN THE ENGINE WITHOUT AIR-INTAKE DUCT INSTALLED (FIG. 4). MAKE SURE BOTTOM LIP OF AIR INTAKE DUCT SITS BETWEEN BATTERY AND LIP OF BATTERY TRAY.

4. Mowing Tips

NOTE: TIRE CHAINS CANNOT BE USED WITH THE MOWER HOUSING ATTACHED.



READ THE "SAFETY RULES" CAREFULLY BEFORE OPERATING YOUR MOWER. REFER TO PAGE 2.

- Use the runner on the R.H. side as a guide; the blade cuts approximately 2.54 cm (1 inch) outside the runner (Fig. 16).

- Drive so that clippings are discharged onto the area that has been cut. Have the cut area to the right of the machine. This will result in a more even distribution of clippings and more uniform cutting.
- When mowing large areas (Fig. 17), start by turning to the right so that the clippings will discharge away from shrubs, fences, driveways, etc. After one or two rounds, mow in the opposite direction making left hand turns until finished.
- If grass is extremely tall, it should be mowed twice. The first time cut relatively high; the second time to the desired height.
- The left hand side of mower should be used for trimming.
- Do not mow tall, dry grass over 15.25 cm (6 inches) tall. It is a fire hazard.

5. Operating The Tractor On Hills



DO NOT DRIVE UP OR DOWN HILLS WITH SLOPES GREATER THAN 15° AND DO NOT DRIVE ACROSS ANY SLOPE. REFER TO PAGE 51.

- Move gear shift lever to "1ST" gear before starting up or down hills.
- AVOID STOPPING OR SHIFTING ON HILLS.
- If slowing is necessary, move throttle control lever to slower position.



LEAVE ENOUGH ROOM WHEN STOPPING AND STARTING TO ALLOW SLIGHT TRACTOR ROLL DOWNHILL AS CLUTCH/ BRAKE PEDAL MOVES THROUGH CLUTCH POSITION.

- If stopping is absolutely necessary push clutch/brake pedal quickly to brake position and engage parking brake.
- To restart tractor movement, make sure tractor is in the lowest speed range ("1ST" Gear) and that you have allowed room to roll slightly downhill. Depress clutch/brake full. Disengage parking brake and release clutch/brake pedal SLOWLY to start tractor movement.
- Make all turns gradually.

6. Flip-Up Discharge Guard

Your mower has a flip-up discharge guard (Fig. 16) for door or gate clearance when held in raised position.



MAKE SURE ATTACHMENT CLUTCH SWITCH IS IN "DISENGAGED" POSITION AND BLADES HAVE STOPPED BEFORE RAISING DISCHARGE GUARD (DEFLECTOR). NEVER OPERATE MOWER WITHOUT DISCHARGE GUARD IN OPERATING POSITION.

MAINTENANCE

To keep your tractor running better, longer, perform necessary service using the following maintenance schedule:

BEFORE MAKING ANY INSPECTION, ADJUSTMENT OR REPAIR:

1. PUSH TRACTOR CLUTCH/BRAKE PEDAL COMPLETELY INTO BRAKE POSITION.
2. MOVE GEAR SHIFT LEVER TO "NEUTRAL" POSITION.
3. PLACE PARKING BRAKE IN "ENGAGED" POSITION. REMOVE FOOT FROM PEDAL.
4. PLACE ATTACHMENT CLUTCH SWITCH IN "DISENGAGED" POSITION.
5. TURN IGNITION KEY TO "OFF" POSITION.
6. MAKE ABSOLUTELY SURE THE BLADES AND ALL MOVING PARTS HAVE COMPLETELY STOPPED.
7. REMOVE THE IGNITION KEY.
8. DISCONNECT THE SPARK PLUG WIRES FROM THE SPARK PLUGS AND KEEP AWAY FROM THE SPARK PLUGS TO PREVENT INJURY FROM ACCIDENTAL STARTING. BE CAREFUL TOO AVOID TOUCHING HOT ENGINE OR MUFFLER COMPONENTS.

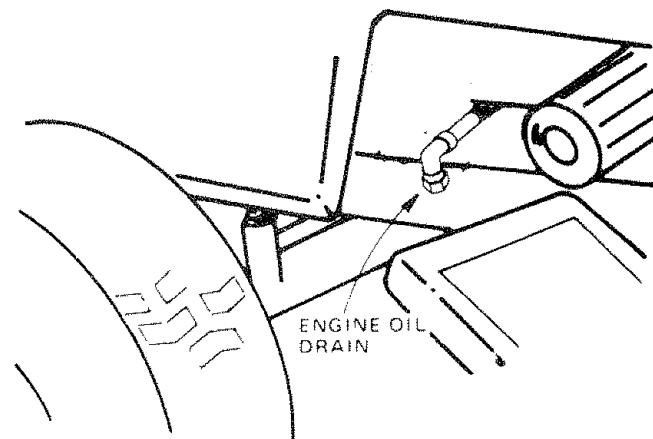
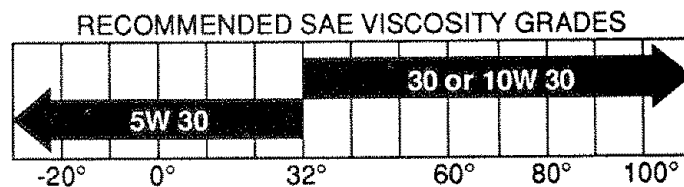

FIGURE 18

Recommended SAE Viscosity Grades

Determine temperature range expected before next oil change. All oil must meet A.P.I. service classification SD, SE or SF.



Dipstick assembly must be securely tightened into tube at all times when engine is operating.

CAUTION: TO AVOID DAMAGE TO THE STARTING SYSTEM, USE SAE 5W30 OIL WHEN THE TEMPERATURE FALLS BELOW 0°C (32°F).

Every 5 Hours (Five Mowings)

1. Check Engine Oil Level



DO NOT CHECK ENGINE OIL LEVEL WITH ENGINE RUNNING.

Several minutes after stopping engine, check engine oil level with tractor on level ground. Wipe dipstick (Fig. 19) clean, screw it down tight for a few seconds, remove and read oil level. If necessary, add oil until "FULL" mark is reached. (See chart above). NOTE: DO NOT OVERFILL.

another free manual from www.seartractormanuals.com

With Every Mowing

Make sure all nuts on bolts are tight and cotter pins and retainer springs are secure. Observe all safety precautions. Keep tractor well lubricated (refer to page 19).

First 2 Hours (Two Mowings)

Change Engine Oil

Changing oil after the first two hours (or two mowings) will help eliminate break-in residue which might be damaging to your engine.

NOTE: BE CAREFUL NOT TO ALLOW DIRT TO ENTER THE ENGINE WHEN CHANGING OIL.

- a. Drain oil with engine warm.
- b. Loosen oil drain plug (Fig. 18) and remove dipstick.
- c. Catch oil in a suitable container.
- d. Tighten oil drain plug.
- e. Refill engine oil (see below). Refill capacity is 1.4 litres (1-1/2 quarts).

NOTE: DO NOT OVERFILL.

- f. Replace dipstick (fig. 19).

MAINTENANCE

Every 25 Hours (Twice a Mowing Season)

1. Brake Adjustment

This Tractor is equipped with an adjustable brake system mounted on the right side of the transaxle (Fig. 20).



IF TRACTOR REQUIRES MORE THAN 1.8 METRES (SIX FEET) STOPPING DISTANCE IN HIGHEST GEAR, THEN BRAKE MUST BE ADJUSTED.

- Depress clutch/brake pedal and engage parking brake.
- Measure distance between brake operating arm and nut "A" on brake rod.
- If distance is other than 3.8 cm (1-1/2"), loosen jam nut (Fig. 20) and turn nut until distance becomes 3.8 cm (1-1/2"). Retighten jam nut against nut "A".

Road test tractor for proper stopping distance as stated above. Readjust if necessary.

2. Tire Care

- Maintain tire pressure in front at 14 PSI (1 Kg/cm²) and rear tires at 10 PSI (0.7 Kg/cm²).
- Keep tires free of gasoline, oil, or insect control chemicals which can harm rubber.
- Avoid stumps, stones, deep ruts and other hazards that may cause tire damage.

3. Blade Sharpening

For best results mower blades must be kept sharp. The blades can be sharpened with a few strokes of a file or on a grinding wheel. We suggest they be sharpened after every 25 hours of mowing. Do not attempt to sharpen while on mower. If you mow in sandy soil check the blades after each two mowings. The sand wears the blades away rapidly.

- When grinding, care should be taken to maintain blade balance and the blade should be checked for proper balance before reinstallation on mower. Unbalanced or bent blade will cause excessive vibration when running, and eventual damage to mower or engine. Replace bent or damaged blades.
- To check blade balance, drive a nail into a beam or wall. Leave about one inch of the straight nail exposed. Place center hole of clean blade over the head of the nail (Fig. 21). NOTE: CENTER HOLE OF BLADE ON NAIL. IF BLADE IS PROPERLY BALANCED, BLADE SHOULD REMAIN IN POSITION SHOWN IN FIG. 21. IF EITHER END OF THE BLADE MOVES DOWNWARD, BLADE IS NOT BALANCED. SHARPEN THE HEAVY END UNTIL BLADE IS BALANCED.

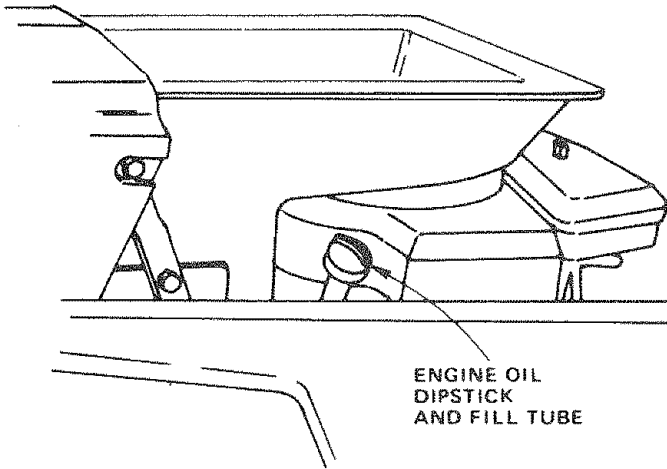

FIGURE 19

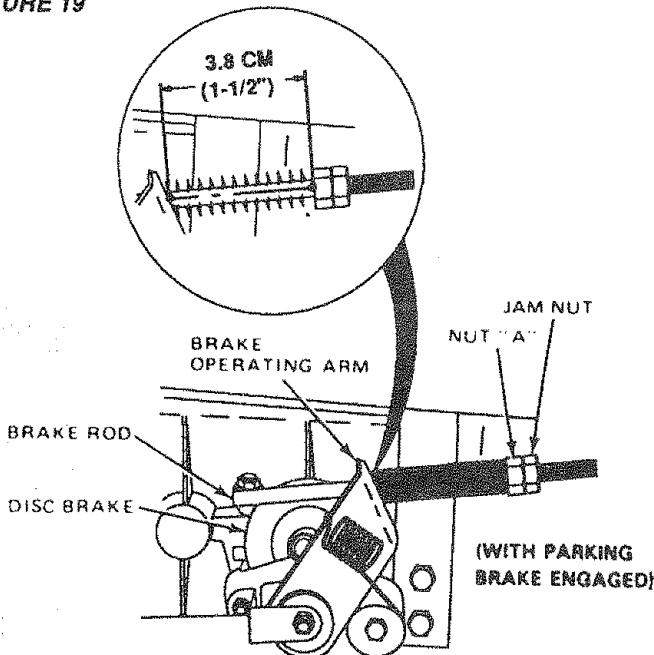

FIGURE 20

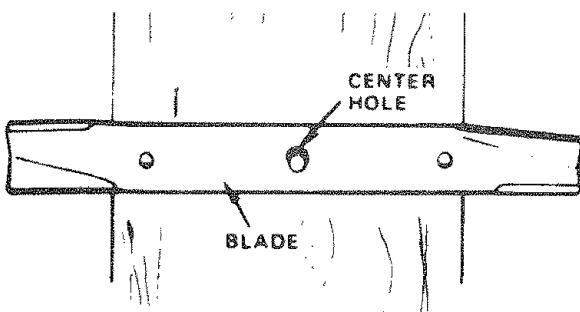

FIGURE 21

MAINTENANCE

Every 50 Hours (Once a Mowing Season)

(Operating in dusty conditions may require more frequent servicing.)

1. Check Battery

- Battery acid level in each battery cell should be even with bottoms of tubes in cells (Fig. 22). Add **ONLY** distilled water if necessary. **NOTE: DO NOT OVERFILL.**
- Keep battery and terminals clean.
- Keep battery bolts tight.
- Keep vent caps tight and small vent holes in caps open.
- Recharge at 6 amperes for 1 hour if necessary.

NOTE: OVERCHARGING WILL SHORTEN BATTERY LIFE.

2. Clean Battery and Terminals

Corrosion and dirt on the battery and terminals cause the battery to "leak" power.



LEAD-ACID BATTERIES GENERATE EXPLOSIVE GASES. KEEP SPARKS, FLAME AND SMOKING MATERIALS AWAY FROM BATTERIES. ALWAYS SHIELD YOUR EYES AROUND BATTERIES.

- Remove terminal guard.
- Disconnect **BLACK** battery cable then **RED** battery cable and remove battery from tractor.
- Wash battery with 6 grams (1/4 cup) of baking soda to 3.8 litres (1 gallon) water.

NOTE: BE CAREFUL NOT TO GET THE SODA SOLUTION INTO THE CELLS.

- Rinse the battery with plain water, dry and reinstall on tractor.
- Clean terminals and battery cable ends with wire brush until bright.
- Replace battery cables, connecting **RED** battery cable to positive terminal first, then **BLACK** battery cable to negative terminal. Coat terminal connections with petroleum jelly.
- Replace terminal guard.

3. Change Engine Oil

The best time to change engine oil is at the end of a day's operation when all dirt and foreign materials are suspended in the hot oil. See chart, page 15.

(OPERATING IN DUSTY CONDITIONS MAY REQUIRE MORE FREQUENT SERVICING)

4. Clean Air Cleaner Foam Pre-Cleaner (Fig. 23)

- Remove Knob and cover.
- Remove foam pre-cleaner element by sliding it off of the paper cartridge.
- Wash foam pre-cleaner in liquid detergent and water.
- Wrap foam pre-cleaner in cloth and squeeze dry.
- Lightly coat foam pre-cleaner with engine oil (Do not saturate). Squeeze in rag or towel to remove excess oil.
- Install foam pre-cleaner over paper cartridge. Reassemble cover and screw down tight.

CUT AWAY VIEW

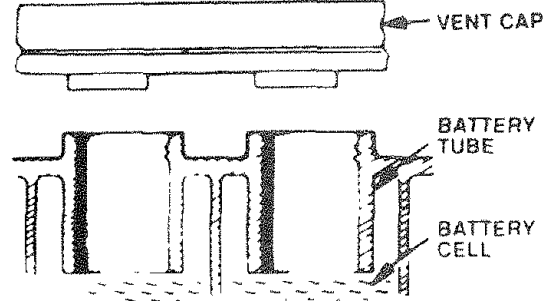

FIGURE 22

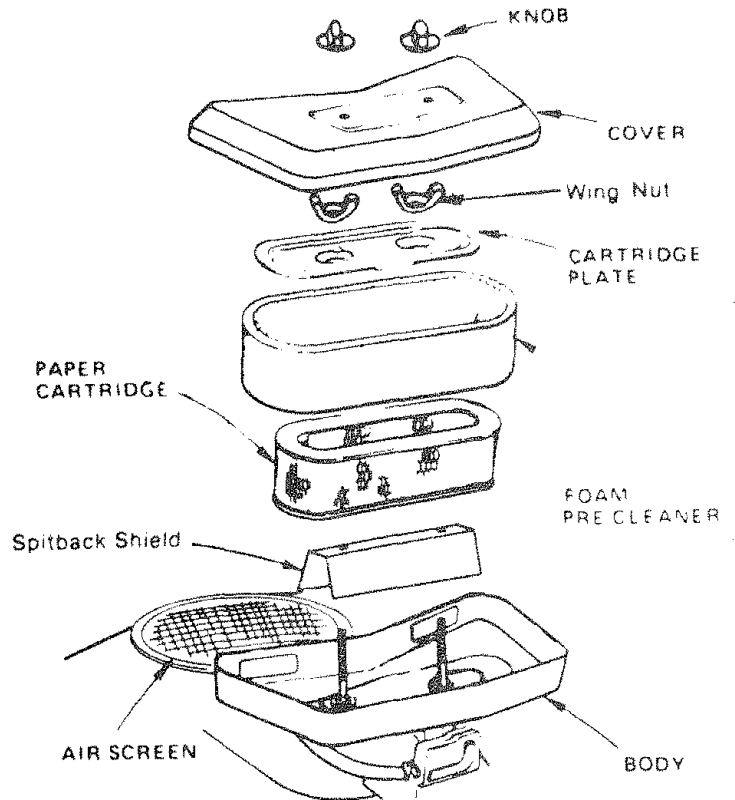

FIGURE 23

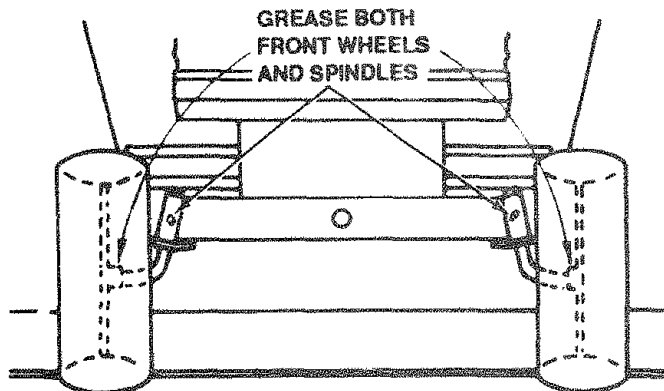

FIGURE 24

MAINTENANCE

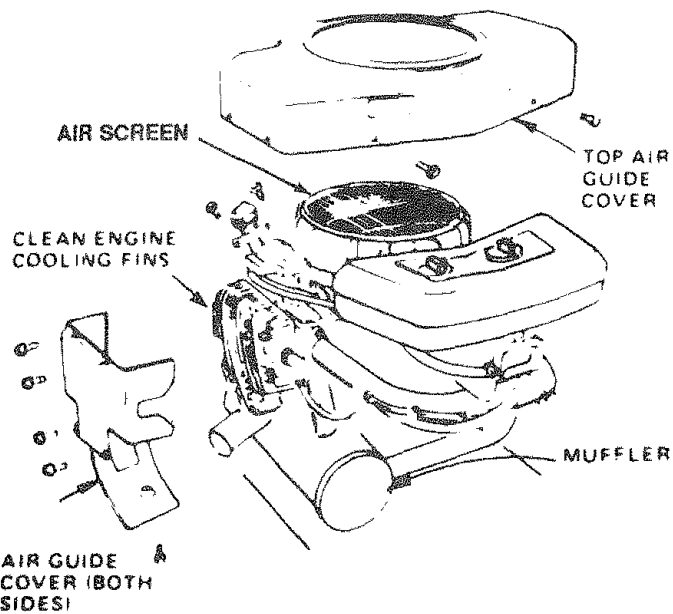

FIGURE 25

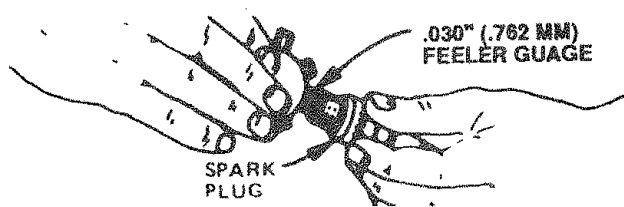

FIGURE 26

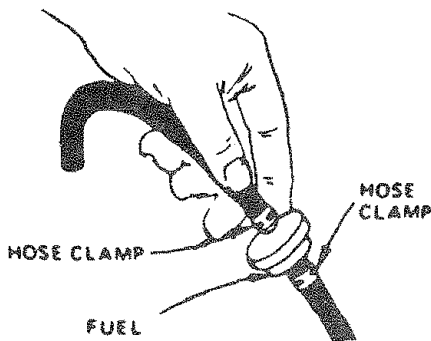

FIGURE 27

5. Lubricate Steering and Front Wheels

There is a grease fitting on each front wheel and axle spindle. Use a grease gun to give each grease fitting two shots of extreme pressure lubricating grease (available through your Sears Service Centre)(Fig. 24).

6. Oil Pivot Points

Place several drops of SAE 30 oil at points where metal parts move against each other, especially:

- Hood hinges.
- Shifter shaft points.

SEE LUBRICATION CHART, PAGE 19.

7. Clean Air Screen

Air screen (Fig. 25) must allow free-flow of air to prevent engine damage from overheating. Clean with a wire brush, compressed air or water pressure to remove dirt, chaff, stubborn dried gum and fibers.

ALWAYS WEAR SAFETY GLASSES WHEN USING COMPRESSED AIR.



DO NOT TOUCH HOT MUFFLER, CYLINDER OR FINS AS CONTACT MAY CAUSE BURNS.

8. Check Muffler

Inspect and replace corroded muffler as it could create a fire hazard and/or damage.

9. Clean Engine Cooling Fins

Remove any dust, dirt or oil from engine cooling fins to prevent engine damage from overheating. Air guide covers must be removed (Fig. 25). Remove eight 7/16" bolts and six 5/16" bolts to remove side and top covers. See "HOOD REMOVAL," page 21.



DO NOT TOUCH HOT MUFFLER, CYLINDER OR FINS AS CONTACT MAY CAUSE BURNS.

Every 100 Hours



DISCONNECT SPARK PLUG WIRES TO PREVENT ACCIDENTAL STARTING BEFORE MAKING ANY INSPECTION, ADJUSTMENT OR REPAIR (EXCEPT CARBURETOR). BE CAREFUL TO AVOID TOUCHING HOT ENGINE OR MUFFLER COMPONENTS.

1. Replace Spark Plugs

Replace spark plugs at the beginning of each mowing season or every 100 hours, whichever comes first. Gap should be set at 0.762 mm (0.030"). (Fig. 26).

2. Replace Air Cleaner Paper Cartridge

Refer to page 17.

3. Replace In-Line Fuel Filter

If fuel filter is clogged, obstructing fuel flow to carburetor, replacement is required.

- With engine cool, remove filter and plug fuel line sections as removed from both ends of fuel filter (Fig. 27).
- Place new fuel filter in position in fuel line.



BE SURE THERE ARE NO FUEL LINE LEAKS AND THAT FUEL LINE IS IN PROPER POSITION IN HOSE CLAMPS.

MAINTENANCE

Lubrication

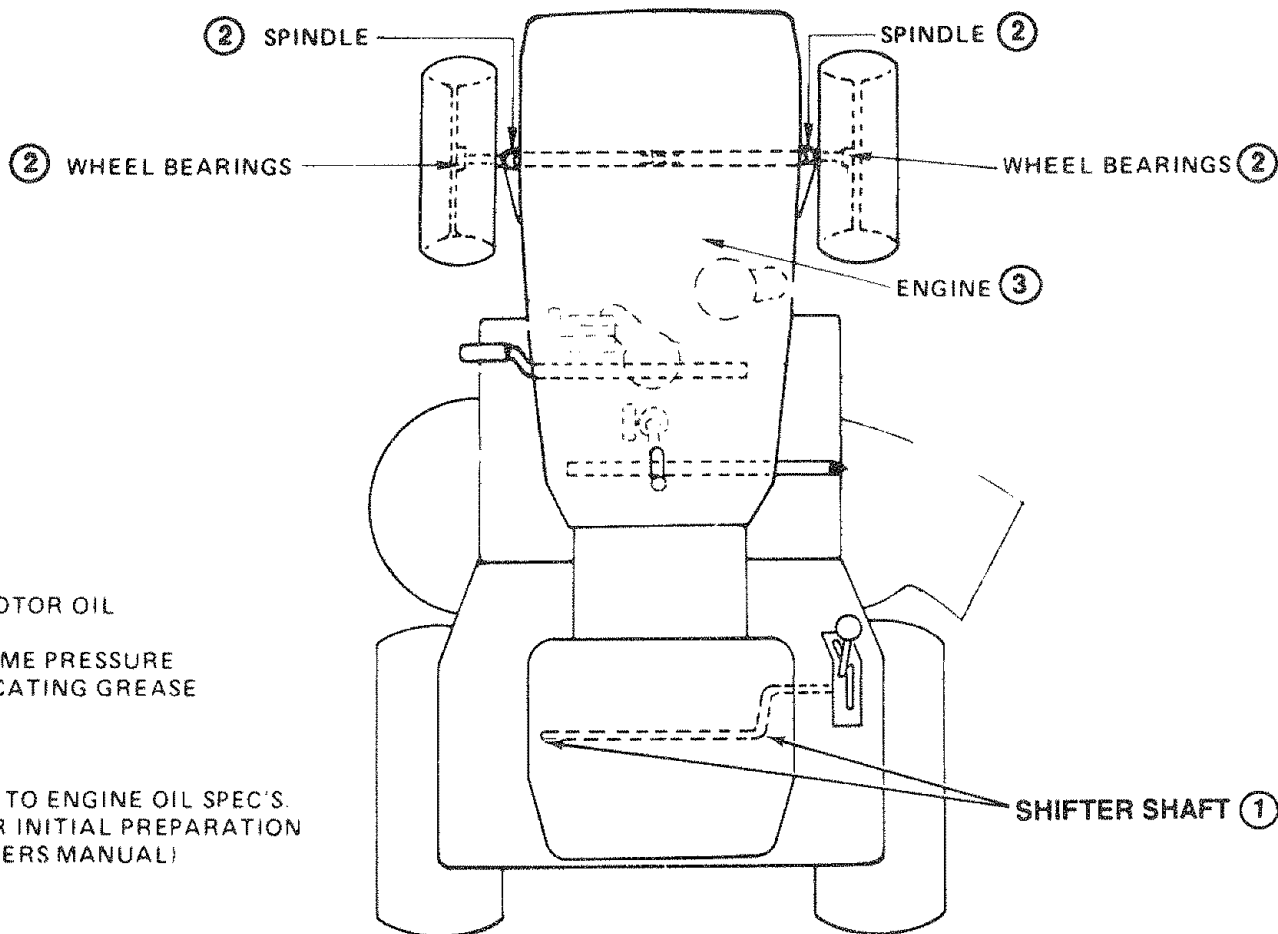

① SAE MOTOR OIL

② EXTREME PRESSURE LUBRICATING GREASE

③ REFER TO ENGINE OIL SPEC'S. (UNDER INITIAL PREPARATION IN OWNERS MANUAL)

REPAIR & ADJUSTMENT

FOR ANY ADJUSTMENTS, INSPECTION OR MAINTENANCE:

1. PUSH TRACTOR CLUTCH/BRAKE PEDAL COMPLETELY INTO BRAKE POSITION.
2. MOVE GEAR SHIFT LEVER TO "NEUTRAL" POSITION.
3. PLACE PARKING BRAKE IN "ENGAGED POSITION". REMOVE FOOT FROM PEDAL.
4. PLACE ATTACHMENT CLUTCH SWITCH IN "DISENGAGED" POSITION.
5. TURN IGNITION KEY TO "OFF" POSITION.
6. MAKE ABSOLUTELY SURE THE BLADES AND ALL MOVING PARTS HAVE COMPLETELY STOPPED.
7. REMOVE THE IGNITION KEY.
8. DISCONNECT THE SPARK PLUG WIRES FROM THE SPARK PLUGS AND KEEP AWAY FROM THE SPARK PLUGS TO PREVENT INJURY FROM ACCIDENTAL STARTING. BE CAREFUL TOO AVOID TOUCHING HOT ENGINE OR MUFFLER COMPONENTS.



NEGATIVE (BLACK CABLE) TERMINAL

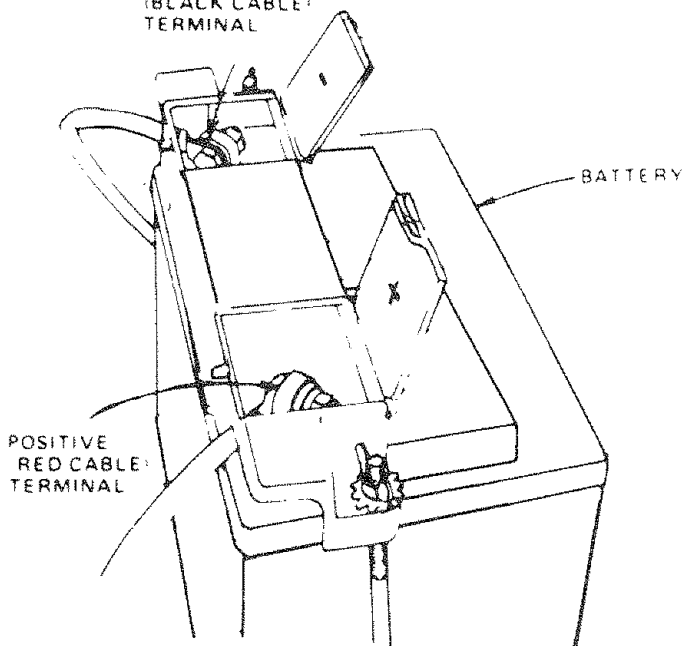

FIGURE 28

REPAIR & ADJUSTMENTS



LEAD-ACID BATTERIES GENERATE EXPLOSIVE GASES. KEEP SPARKS, FLAME AND SMOKING MATERIALS AWAY FROM BATTERIES. ALWAYS WEAR EYE PROTECTION WHEN AROUND BATTERIES.

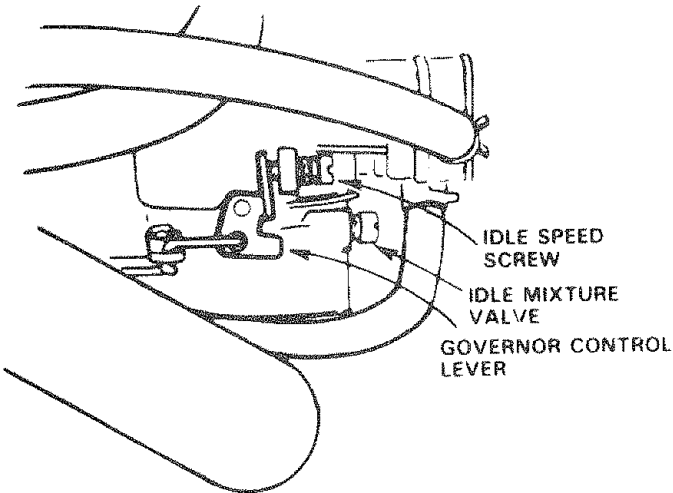

FIGURE 29

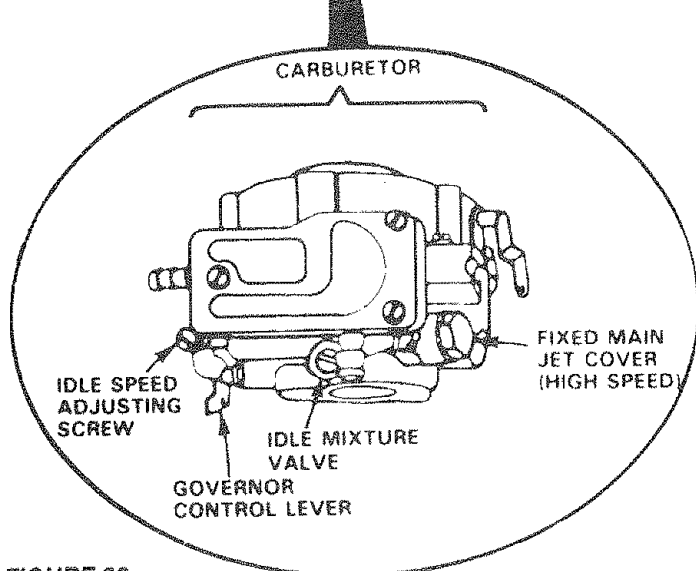
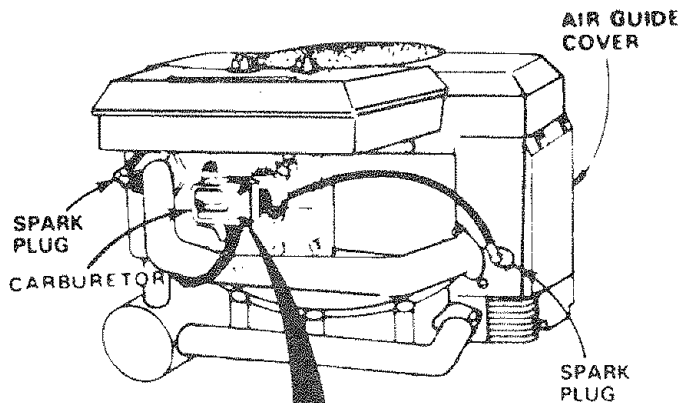

FIGURE 30

1. Starting your Tractor With a Weak Battery

If your battery is too weak to start the engine, it should be recharged. If "jumper cables" are used for emergency starting, follow this procedure:

NOTE: YOUR TRACTOR IS EQUIPPED WITH A 12 VOLT NEGATIVE GROUNDED SYSTEM. THE OTHER VEHICLE MUST ALSO BE A 12 VOLT NEGATIVE GROUNDED SYSTEM.

- Connect each end of the **RED** jumper cable to the **POSITIVE(+)** terminals of each battery (taking care not to short against chassis). (Fig. 28)
- Connect one end of the **BLACK** jumper cable to the **NEGATIVE (-)** terminal of fully charged battery.
- Connect the other end of the **BLACK** jumper cable to the L.H. side panel bolt (Fig. 14) NOTE: KEEP AWAY FROM GAS TANK AND BATTERY.
- Disconnect cables in reverse order:
 - L.H. side panel bolt (Fig. 14)
 - Negative terminal of fully charged battery
 - Positive terminals



DO NOT USE YOUR TRACTOR BATTERY TO START OTHER VEHICLES.

2. Throttle Control Cable Adjustment

Never attempt to change maximum engine speed. This is preset at the factory (3600 ± 100 RPM) and should only be changed by a qualified service technician who has the necessary equipment.

- Remove hood (page 21).
- Loosen casing clamp screw until throttle cable is free to move.
- Move throttle control (on the dashboard) to "FAST" position.
- Pull throttle cable tight (until swivel below carburetor is against side of quarter circle). Retighten casing clamp screw.



REFER TO "STARTING THE ENGINE," PAGE 12.

3. Carburetor Adjustment

NOTE: ADJUST THROTTLE CONTROL CABLE BEFORE MAKING ANY ADJUSTMENT TO CARBURETOR. AIR CLEANER MUST BE ASSEMBLED TO CARBURETOR WHEN RUNNING ENGINE.

Minor carburetor adjustments may be required to compensate for differences in fuel, temperature or altitude. Adjust the carburetor fuel mixture as follows:

- Gently turn idle mixture valve clockwise (↻) (Fig. 30) until it just closes and then counterclockwise (↺) 1-1/2 turns. CAUTION: Valve may be damaged if turned in too far.
- Start engine and allow to warm for five minutes. Make final adjustments with engine running and choke pushed in.
- Move throttle control lever (on dashboard) to "SLOW" position.

REPAIR & ADJUSTMENT

- d. Hold governor control lever against idle speed screw, and adjust idle speed screw to obtain 1200 to 1400 RPM (Fig. 29).
- e. While still holding the governor control lever against idle speed screw, turn idle mixture valve slowly clockwise (↻) (lean mixture) until speed just starts to slow.
- f. Turn idle mixture valve back to the midpoint between rich and lean.
- g. Adjust the idle speed screw to obtain 900 to 1200 RPM. Release governor control lever.
- h. Move throttle control (on the dashboard) to "FAST." If engine hesitates or dies, turn idle mixture valve approximately 1/8 turn counterclockwise (↺) until engine will accelerate as throttle control is moved from "SLOW" to "FAST."

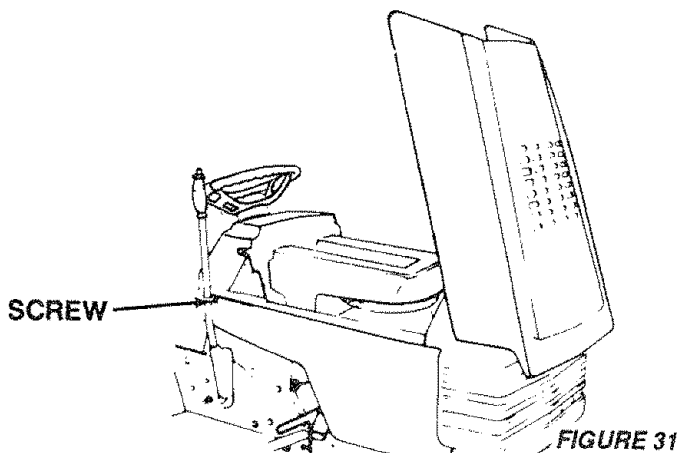

FIGURE 31

Fuse Replacement

Replace with 30 amp automotive-type plug in fuse. Fuses can be purchased at all Sears Service Centres and most retail stores. Fuse is located directly behind dash.

Hood Removal

- a. Lift hood. Disconnect headlight wiring connection (Fig. 32).
- b. Unscrew one screw at rear of each side panel (Fig. 31).
- c. Pivot hood and side panel forward and lift off tractor (Fig. 32).
- d. To replace, reverse above procedure.

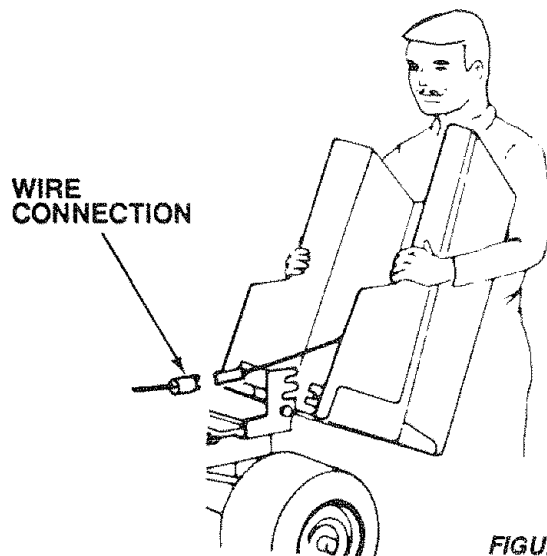

FIGURE 32

Mower Adjustment

Adjust the mower while tractor is parked on level ground or driveway. Make sure tire pressures are 1 Kg/cm² (14 PSI) in front and 0.71 Kg/cm² (10 PSI) in rear. If tires are over or under inflated, you will not properly adjust your mower.

FOR ANY ADJUSTMENTS, INSPECTION OR MAINTENANCE:

1. PUSH TRACTOR CLUTCH/BRAKE PEDAL COMPLETELY INTO "BRAKE" POSITION.
2. MOVE GEAR SHIFT LEVER TO "N" (NEUTRAL) POSITION.
3. PLACE PARKING BRAKE IN "ENGAGED" POSITION. REMOVE FOOT FROM PEDAL.
4. PLACE ATTACHMENT CLUTCH SWITCH IN "DISENGAGED" POSITION.
5. TURN IGNITION KEY TO "OFF" POSITION.
6. MAKE ABSOLUTELY SURE THE BLADES AND ALL MOVING PARTS HAVE COMPLETELY STOPPED.
7. REMOVE THE IGNITION KEY.
8. DISCONNECT THE SPARK PLUG WIRE(S) FROM THE SPARK PLUG(S) AND KEEP WIRE(S) AWAY FROM THE PLUG(S) TO PREVENT INJURY FROM ACCIDENTAL STARTING. BE CAREFUL TO AVOID TOUCHING HOT ENGINE OR MUFFLER COMPONENTS.

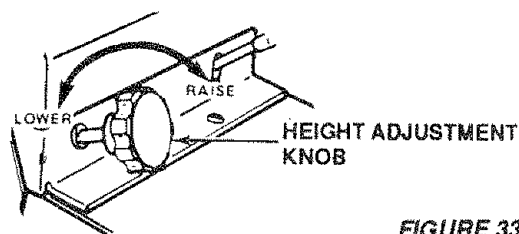

FIGURE 33

Height Adjustment

Adjustment for mower height is made with the height adjustment knob. Raise mower cutting height by turning height adjustment knob clockwise (↻). Lower mower cutting height by turning height adjustment knob counterclockwise (↺). (Fig. 33).

Side-to-Side mower Adjustment

- a. Depress lift lever plunger and use lift lever to raise mower to maximum cutting height (Fig. 34).
- b. Measure height from bottom of curl to ground level at front of mower. Distance "A" should be the same (Fig. 34).

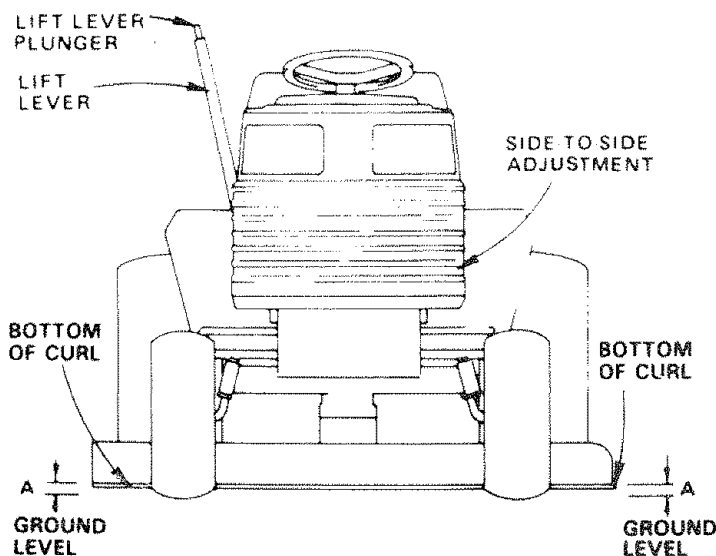

FIGURE 34

REPAIR & ADJUSTMENT

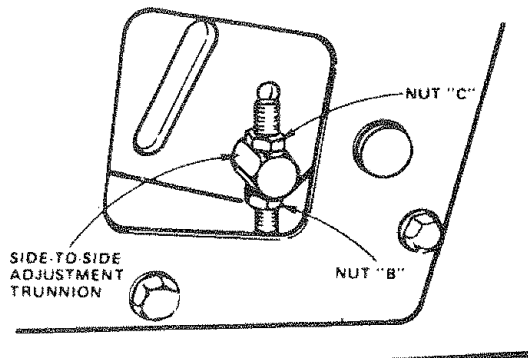

FIGURE 35

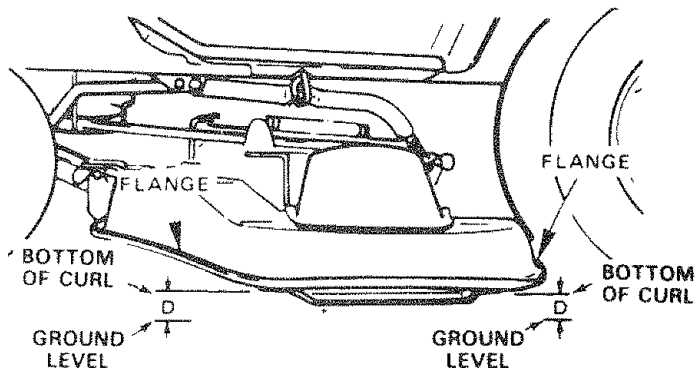

FIGURE 36

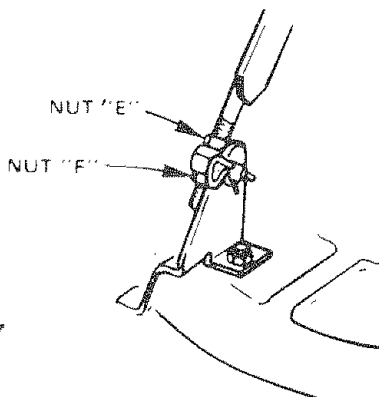

FIGURE 37

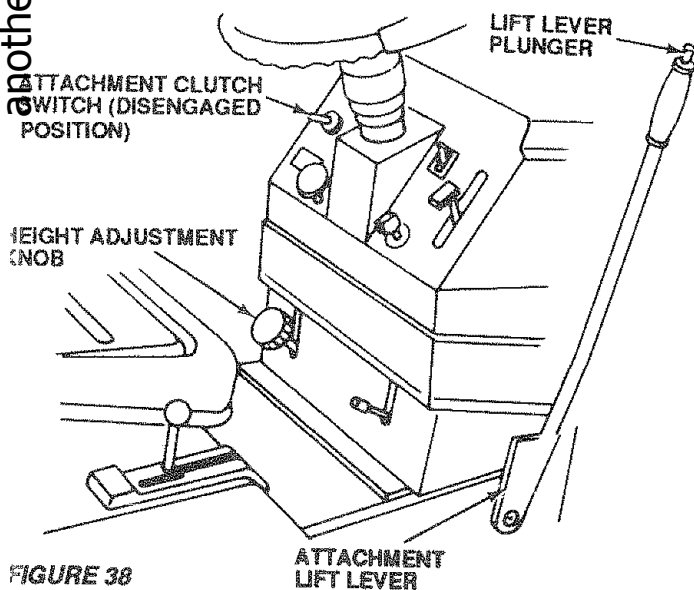

FIGURE 38

- c. If distance "A" needs to be changed, snap out access hole cover on L.H. side above footrest. Use 11/16" wrench on nuts "B" and "C" at side-to-side adjustment trunnion (Fig. 35).
- d. To raise left side of mower, loosen nut "B" and tighten nut "C".
- e. To lower left side of mower, loosen nut "C" and tighten nut "B".

NOTE: ONE ROTATION OF ADJUSTMENT NUTS IS EQUIVALENT TO APPROXIMATELY 5 MM (3/16") HEIGHT CHANGE.

- f. Be sure all nuts are securely tightened.

Front-To-Rear Mower Adjustment

- a. To obtain the best cutting results, your mower housing should be adjusted so the front and rear flange distance "D" (Fig. 36) is 13 mm (1/2") lower in front when the mower is positioned in the highest cutting position.

NOTE: MEASURE DISTANCE "D" FROM GROUND LEVEL TO BOTTOM OF CURL ON RIGHT REAR FLANGE AND COMPARE TO DISTANCE "D" AT RIGHT FRONT FLANGE.

- b. To raise rear of mower, loosen nut "E" on both rear suspension arms. Screw both nuts "F" up an EQUAL NUMBER OF TURNS (Fig. 41).
- c. When distance "D" is 13 mm (1/2") lower at front than rear, tighten nuts "E".
- d. To lower rear of mower, loosen nut "F" on both rear suspension arms an EQUAL NUMBER OF TURNS (Fig. 37).
- e. When distance "D" is 13 mm (1/2") lower at front than rear, retighten nuts "E".

NOTE: WHEN ADJUSTING REAR SUSPENSION TRUNNIONS, ALWAYS ADJUST BOTH EQUALLY SO MOWER WILL STAY LEVEL.

Mower Drive Belt Removal

NOTE: MOWER BELT INSTALLATION DECAL LOCATED ON MOWER HOUSING.



REPLACE ONLY WITH THE BELTS SPECIFIED IN THIS MANUAL.

- a. Place attachment clutch switch in "Disengaged" position (Fig. 38).
- b. Turn height adjustment knob to its lowest position. Move attachment lift lever (Fig. 38) forward to lower mower to its lowest position.
- c. Roll belt off engine pulley (Fig. 39).
- d. Pull belt off both mower pulley and idler pulleys (Fig. 40).
- e. To replace mower drive belt, reverse above procedure.

NOTE: MAKE SURE DRIVE BELT IS ENGAGED IN ALL PULLEYS.

REPAIR & ADJUSTMENT

another free manual from www.seartractormanuals.com

7. Mower Removal

- Remove mower drive belt. (See "MOWER DRIVE BELT REMOVAL," page 22, through step 3.)
- Pull belt off engine pulley (Fig. 39).
- Pull retainer springs out of rear suspension trunnions. Remove rear suspension trunnions from lift brackets (Fig. 41)
- Pull retainer spring out of rear hinge pin. Remove rear hinge pin (Fig. 41).
- Pull retainer spring out of front hinge pin. Remove front hinge pin (Fig. 41) and parallel link.
- Use lift lever to raise suspension arms. Slide mower out from under tractor.

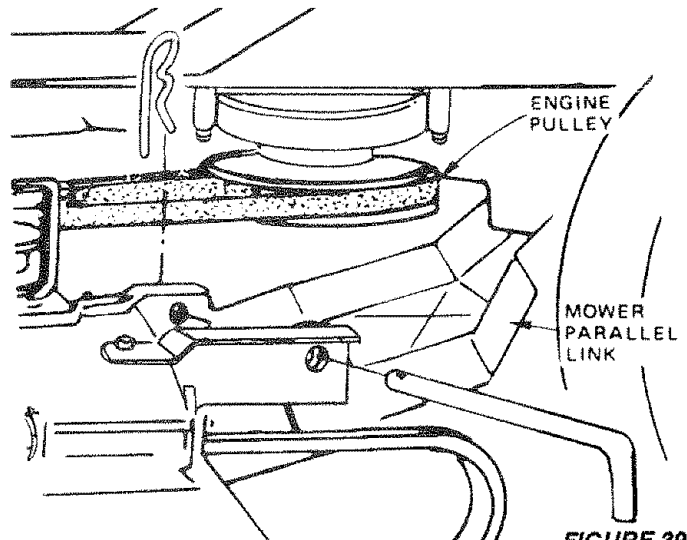

FIGURE 39



BEFORE DRIVING YOUR TRACTOR, INSTALL MOWER OR REMOVE PARALLEL LINK (FIG. 41).

NOTE: IF AN ATTACHMENT OTHER THAN THE MOWER DECK IS TO BE MOUNTED ON THE TRACTOR, THE L.H. AND R.H. SUSPENSION ARMS (FIG. 41) SHOULD BE REMOVED.

Mower Blade Drive Belt Replacement

- Remove mower drive belt. (See page 22.)
- Remove mower from tractor. (See "MOWER REMOVAL," above.)
- Pull belt towards rear of mower at tensioning pulley (Fig. 42). Place a block between tension bracket and mower lift bracket. Roll belt off tensioning pulley.
- Roll belt off all other pulleys.
- Slide belt from under spring.
- To install belt, reverse above procedure. Make sure belt is engaged in all pulleys.

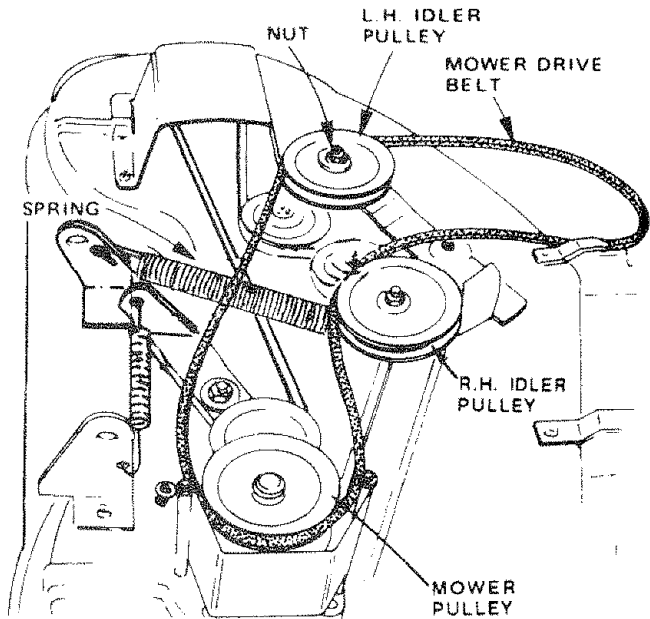

FIGURE 40

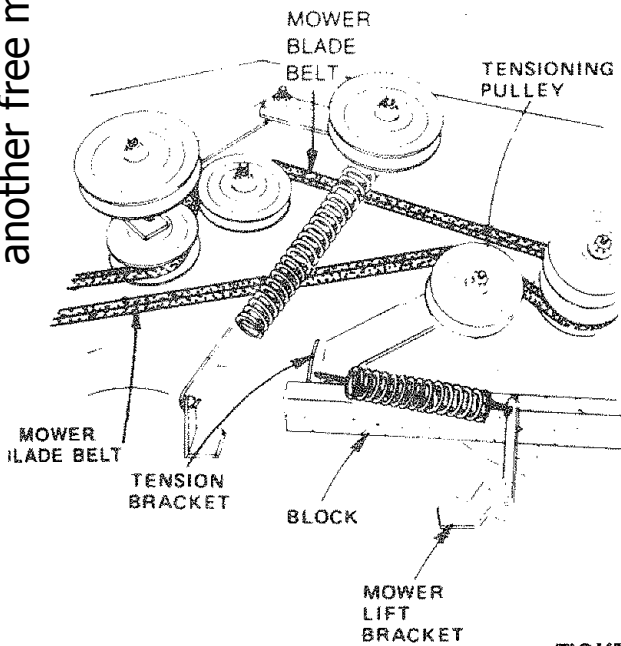

FIGURE 42

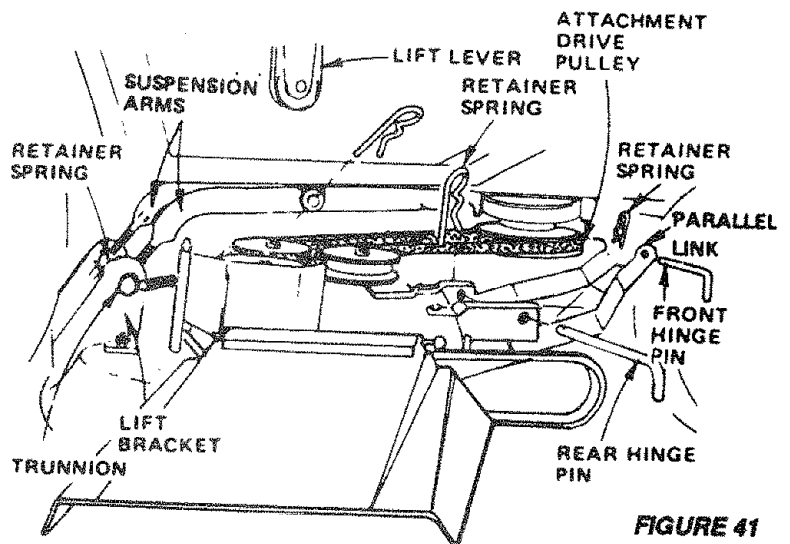

FIGURE 41

REPAIR & ADJUSTMENTS

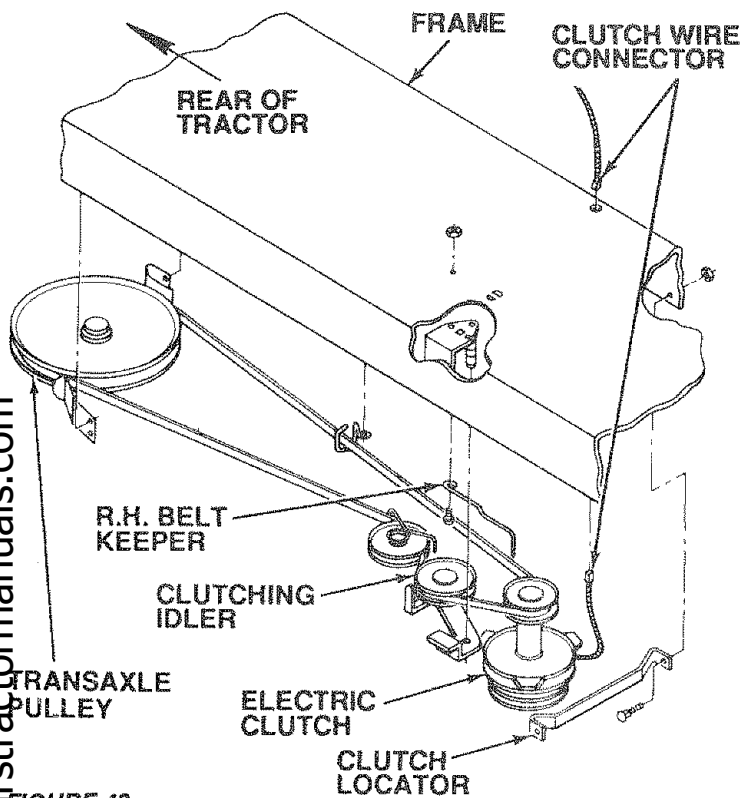

FIGURE 43

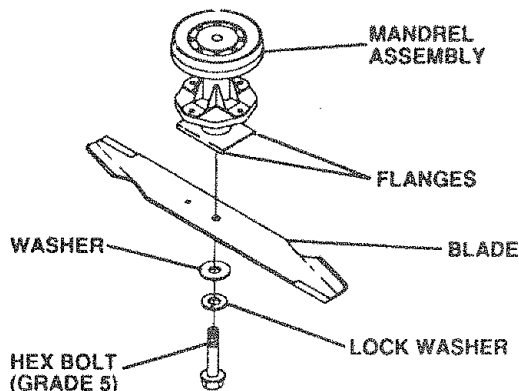

FIGURE 44

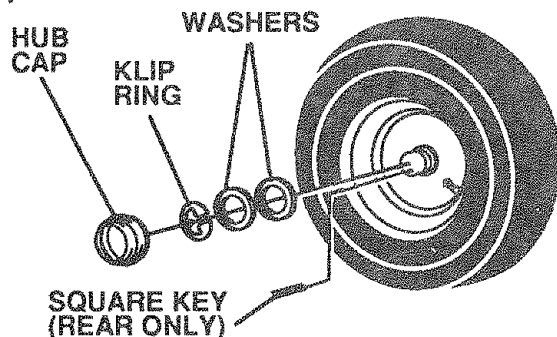
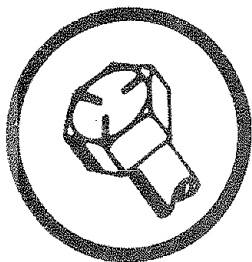

FIGURE 45



A GRADE 5 HEAT TREATED BOLT CAN BE IDENTIFIED BY THREE LINES ON THE BOLT HEAD AS SHOWN AT LEFT.

9. Motion Drive Belt Replacement

NOTE: BELT INSTALLATION DECAL IS LOCATED UNDER LEFT FOOTREST.

- Remove mower (see "MOWER REMOVAL" page 23).
- Using a 1/2" wrench, remove the clutch locator (Fig. 43).
- Using a 9/16" wrench, loosen the right hand belt keeper (Fig. 43).
- Disconnect clutch wire connector. Push connector through frame (Fig. 43).
- Pull belt off clutching idler and raise to top side of pulley.
- Release parking brake. Push belt over and away from clutching idler.
- Pull belt slack toward rear of tractor. Remove belt from transmission pulley by deflecting keepers to force belt up and out of pulley. (Use belt to push keepers away from pulley.) (Fig. 43.)
- Work belt around remaining pulleys and keepers, working toward transaxle pulley.
- Pull belt forward off transaxle pulley and down over electric clutch.
- Reinstall in reverse of above procedure.

Make sure right hand belt keeper is positioned correctly between locator tabs and electric clutch connection is secure.

10. Blade Replacement

Raise mower to highest position to permit access to blades or remove mower.

- Remove bolt, lockwasher and washer (Fig. 44) (turn counterclockwise) (↺).
- Remove and discard old blade.
- Clean top and bottom of mower housing.
- Place new blade between flanges, (Install with sharp edge down), and secure with washer, lockwasher and bolt previously removed.

11. Tire Care

- Maintain tire pressure in front at 14 PSI (1Kg/cm²) and rear tires at 10 PSI (0.7 Kg/cm²).
- Keep tires free of gasoline, oil, or insect control chemicals which can harm rubber.
- Avoid stumps, stones, deep ruts, sharp objects and other hazards that may cause tire damage.
- Removing wheel for tire repair (Fig. 45).
 - Block up axle securely.
 - Remove hub cap, klip ring and washer to allow wheel removal (rear wheel contains a square key - Do Not Lose).
 - Repair tire and reassemble. Align slots in rear wheel hub and axle. Insert square key. Replace washer and snap klip ring securely in axle groove. Replace hub cap.

NOTE: USE GREASE FITTINGS TO LUBRICATE FRONT WHEELS WITH GENERAL PURPOSE GREASE. APPLY AN ANTI-SEIZE OR GOOD GENERAL PURPOSE GREASE TO LUBRICATE REAR AXLES.



ALWAYS USE GRADE 5 HEAT TREATED BOLTS TO ATTACH BLADES. DO NOT USE PLATED BOLTS. CHECK BOLTS IN BLADES OCCASIONALLY TO MAKE SURE BOLTS ARE TIGHT. TORQUE BOLTS TO 41-47 N-m (30-35 FT.-LBS.).

REPAIR & ADJUSTMENT



WHEN MOUNTING TIRES, UNLESS BEADS ARE SEATED, OVER INFLATION CAN CAUSE AN EXPLOSION.

12. Rear Wheel Replacement

For rear wheel replacement, follow instructions under "TIRE CARE," page 24.

Coat axle with grease to prevent corrosion or rust accumulation and eventual seizing of wheel hub to axle shaft.



WHEN REPLACING WHEELS ON THE TRACTOR THEY MUST BE MOUNTED WITH THE LONG HUB SIDE TOWARD THE CENTER OF THE TRACTOR. INCORRECT INSTALLATION COULD AFFECT LATERAL STABILITY. (SEE FIG. 46).

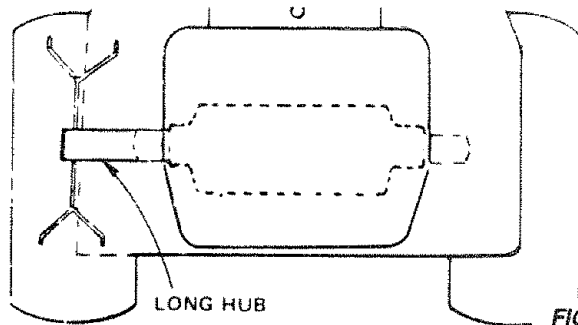

FIGURE 46

3. Transaxle Shifter Linkage Positioning and Adjustment

The transaxle should be in neutral when the gear shift lever is in the neutral (lock gate) position (Fig. 47). The adjustment is preset at the factory; however, if adjustment is needed, proceed as follows:

- Make sure transaxle is in neutral.
- Using a 7/16" wrench, loosen two (2) locknuts on tie rod (Fig. 48 - inset).
- Turn center rod (Fig. 48 - inset) until gearshift lever falls into neutral lock gate on fender console (Fig. 47).
- Tighten locknuts securely.

4. Storage

Remove mower from tractor for winter storage. When mower is to be stored for a period of time, clean it thoroughly, remove all dirt, grease, leaves, etc., give blades and underside of housing a good coat of grease or rust preventative. Store in a clean dry area.

a. Fuel System

It is important to prevent gum deposits from forming in essential fuel system parts such as the carburetor, fuel filter, fuel hose, or tank during storage. Also, experience indicates that alcohol blended fuels (called gasohol or using ethanol or methanol) can attract moisture which leads to separation and formation of acids during storage. Acidic gas can damage the fuel system of an engine while in storage. To avoid engine problems, the fuel system should be emptied before storage of 30 days or longer.

b. Engine Oil

Drain (with engine warm) oil and replace with clean engine oil, (see chart on page 15).

c. Cylinders

- Remove spark plugs.
- Pour 29.5 cc (one ounce) of oil through spark plug hole into cylinder.
- Turn ignition key to "START" position for a few seconds to distribute oil.
- Replace with new spark plugs.

d. Battery

- Prior to storage, clean terminals and top of battery.
- Disconnect cable from positive side of battery.

After a period of time in storage, battery may require recharging.

e. General Cleaning

Clean engine, battery, seat, finish, etc. of all foreign matter.

- Store in a clean, dry area

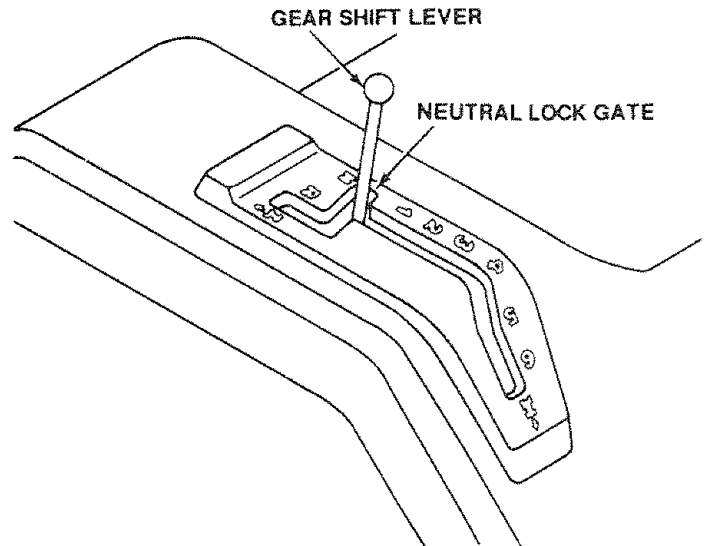

FIGURE 47

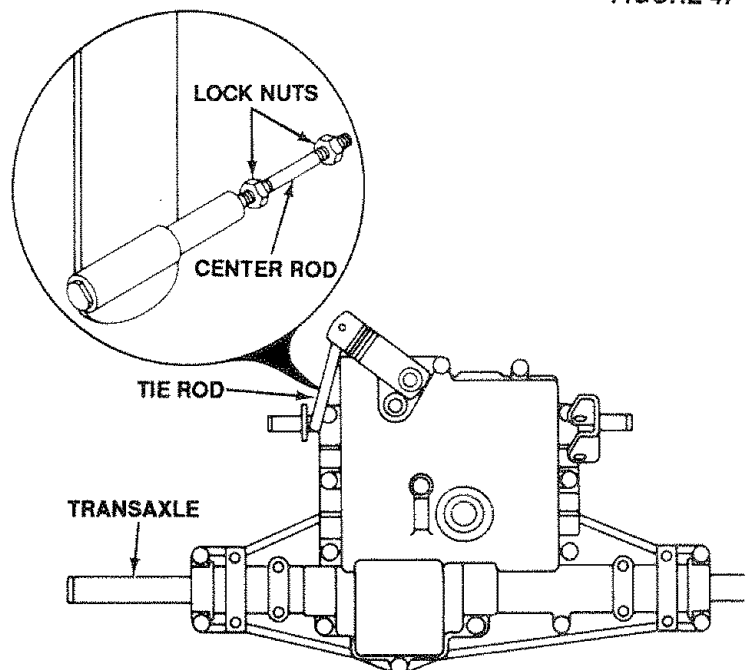

FIGURE 48

TROUBLESHOOTING

PROBLEM	CAUSE / REMEDY (SEE INDEX)
WILL NOT START	<i>Fill Tank with Gasoline. Check Fuel Line and Carburetor (clean if necessary). Replace Fuel Filter. Use Fresh Fuel</i> <i>Recharge or replace Battery</i> <i>Check Wiring</i> <i>Replace Spark Plug(s) and adjust gap</i> <i>Drain and replace oil for proper temperature</i>
WILL NOT TURN OVER	<i>Push Clutch/Brake Pedal into brake position</i> <i>Charge or replace Battery</i> <i>Move Attachment Clutch Switch to "DISENGAGED" position</i> <i>Replace Ignition Switch</i> <i>Replace Interlock Switch(es)</i> <i>Replace Solenoid or Starter</i> <i>Replace Fuse</i> <i>Check all Wire Connections and "Ground" Points</i> <i>Reattach Tiller Attachment Wire Loop</i>
ENGINE CLICKS BUT WON'T START	<i>Clean Battery Terminals</i> <i>Replace Starter or Solenoid</i> <i>Charge or Replace Battery</i> <i>Check Wire Connections and "Ground" Points</i>
HARD TO START	<i>Place Throttle Control in "FAST" position and run starter several times to clear out gas</i> <i>Remove Air Filter and clean</i> <i>Replace Spark Plug(s) and adjust gap</i> <i>Recharge or replace Battery</i> <i>Check the Wiring</i> <i>Drain Fuel Tank and Carburetor. Use Fresh Fuel.</i> <i>Replace Fuel Filter</i> <i>Make necessary adjustments to Carburetor</i> <i>Major Engine Overhaul</i>
ENGINE MISSES OR LACKS POWER	<i>Shift to a lower gear or reduce load</i> <i>Drain Gas Tank and Carburetor. Use Fresh Fuel</i> <i>Remove and clean Air Cleaner</i> <i>Make necessary carburetor adjustments</i> <i>Clean Air Screen</i> <i>Add or change oil</i> <i>Replace Spark Plug(s) and adjust gap</i> <i>Replace Fuel Filter</i> <i>Major Engine Overhaul</i>
ENGINE OVERHEATS	<i>Shift to lower gear or reduce load</i> <i>Clean Air Screen</i> <i>Add or change oil</i> <i>Clean Engine Cooling Fins</i> <i>Remove and clean Muffler or replace</i> <i>Remove and clean Air Filter</i> <i>Use fresh fuel and adjust Carburetor</i>
NO LIGHTS	<i>Check Fuse, Switch and Wire Connections. Replace Headlight Bulbs</i> <i>Replace Switch</i>
WON'T CHARGE	<i>Check Fuse for fault and replace</i> <i>Replace Battery</i> <i>Replace Diode Assembly</i> <i>Replace Alternator</i>
OPERATOR PRESENCE SYSTEM WILL NOT SHUT DOWN ENGINE WHEN OPERATOR LEAVES SEAT <i>NOTE: This tractor is equipped with an operator presence sensing system. Any attempt by the operator to leave the seat with the engine running and the attachment clutch engaged will shut down the engine.</i>	<i>Check all Wire Connections</i> <i>Check Seat Switch</i>

TROUBLESHOOTING

<p>UNSATISFACTORY MOWER PERFORMANCE UNEVEN DISTRIBUTION OF CLIPPINGS</p>	<p>Move Throttle Control to "FAST" Check air pressure in Tires Check front-to-rear and side-to-side Mower adjustment Use a slower ground speed Replace Mower Blades Reinstall Mower Blades with Top of Blade up Clean underside of Mower Deck Readjust Mower Drive Belt</p>
<p>MOWER BLADES WILL NOT ROTATE</p>	<p>Correct Clutch Mechanism Interference Install new Mower Drive Belt Reinstall Mower Drive Belt Adjust Mower Drive Belt Replace frozen Mandrel Replace frozen Idler Pulley</p>
<p>EXCESSIVE MOWER VIBRATION</p>	<p>Replace bent or unbalanced Blades Replace Mandrel. Straighten Deck or replace</p>
<p>WIND ROWING STRIPPING OR DROPPING OF GRASS CLIPPINGS</p>	<p>Set Throttle for maximum engine speed Let grass dry out Clean underside of Mower Deck Readjust Mower front-to-rear and side-to-side Replace Blades</p>
<p>UNEVEN CUT OR SCALPING</p>	<p>Readjust Mower front-to-rear and side-to-side Replace Blades Replace bent Mandrel(s)</p>

another free manual from www.seartractormanuals.com

<p>SERVICE RECORD FILL IN DATES AS YOU COMPLETE REGULAR SERVICE</p>	<p>SERVICE DATES</p>										
	FIRST 2 HOURS	EVERY 8 HOURS	EVERY 25 HOURS	EVERY 50 HOURS	EVERY 100 HOURS	EVERY 200 HOURS					
Change Engine Oil	✓		✓								
Check Brake Operation		✓	✓								
Check Tire Pressure		✓	✓								
Clean Air Screen			✓	✓							
Clean Air Cleaner			✓	✓							
Lubricate Pivot Points (see page 24)			✓	✓							
Check Battery Level and Recharge			✓	✓							
Clean Battery and Terminals			✓	✓							
Carburetor Adjustment			✓	✓							
V-Belt Adjustment			✓	✓							
Clean Engine Cooling Fins				✓	✓						
Check Muffler				✓	✓						
Replace Air Cleaner Paper Cartridge					✓	✓					
Replace Spark Plug					✓	✓					
Replace Fuel Filter						✓	✓				

18 HP GARDEN TRACTOR - - MODEL NUMBER 917.254450 & 917.250020

SCHEMATIC

another free manual from www.searctractormanuals.com

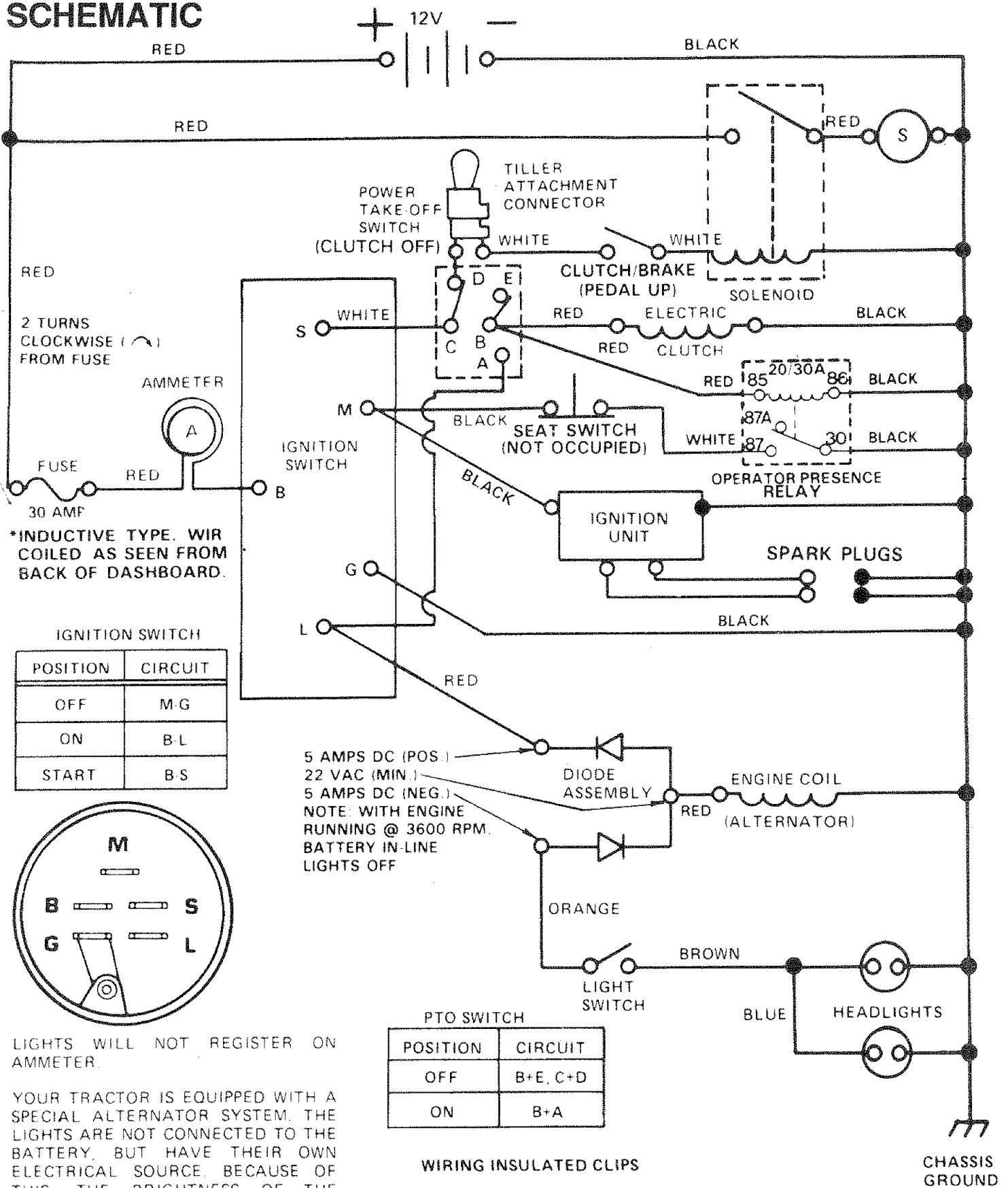

LIGHTS WILL NOT REGISTER ON AMMETER.

YOUR TRACTOR IS EQUIPPED WITH A SPECIAL ALTERNATOR SYSTEM. THE LIGHTS ARE NOT CONNECTED TO THE BATTERY, BUT HAVE THEIR OWN ELECTRICAL SOURCE. BECAUSE OF THIS, THE BRIGHTNESS OF THE LIGHTS WILL CHANGE WITH THE ENGINE SPEED. AT IDLE SPEED THE LIGHTS WILL DIM. AS THE ENGINE IS SPEEDED UP, THE LIGHTS WILL BECOME THEIR BRIGHTEST.

REPAIR PARTS

18 HP GARDEN TRACTOR - - MODEL NUMBER 917.254450 & 917.250020

ELECTRICAL

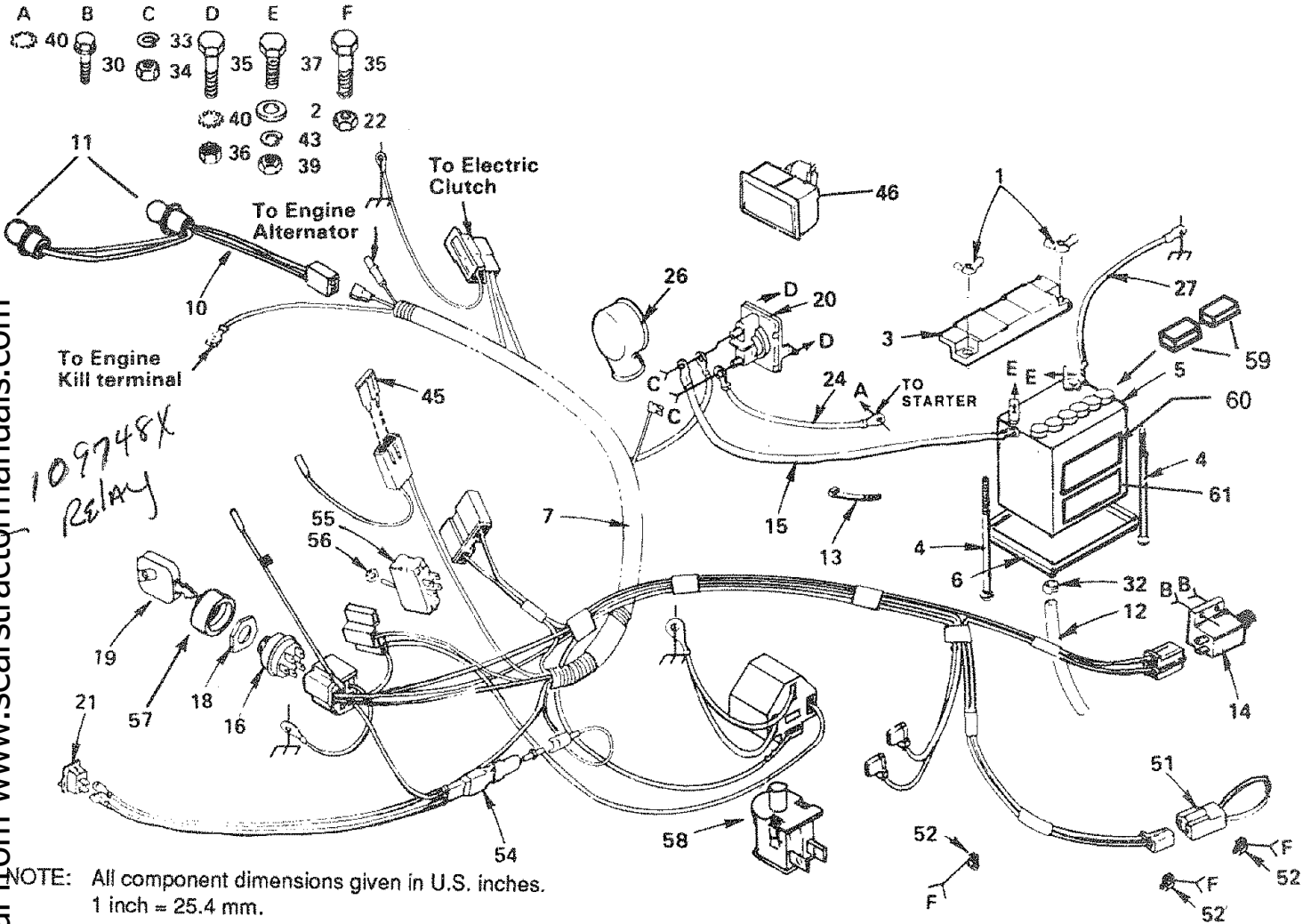

NOTE: All component dimensions given in U.S. inches.
1 inch = 25.4 mm.

KEY PART NO. NO.	DESCRIPTION	KEY PART NO. NO.	DESCRIPTION
1	123198X Wing Nut 1/4 - 20	30	STD601005 * Screw - Tap. Hex Hd. No. 10 - 24 UNC x 1/2 Type T
2	STD551025 * Washer 9/32 x 5/8 x 16 Ga.	32	109596X Clamp - Hose
3	102476X Guard - Terminal	33	STD551125 * Lockwasher 1/4
4	STD532575 * Bolt, Carriage 1/4- 20 x 7- 1/2	34	73350400 * Nut - Hex Jam 1/4 - 20
5	121537X Battery	35	74780408 Bolt-Hex 1/4 - 20 x 1/2 Gr. 5
6	7603J Battery Tray	36	STD541425 * Nut-Keps, Hex 1/4 - 20
7	124561X Harness - Ignition	37	74760412 Bolt-Hex 1/4 - 20 x 3/4
10	110859X Harness - Light Socket	39	STD541025 * Nut-Hex 1/4 - 20
11	4152J Bulb - Light	40	STD551125 Washer - Lock 1/4 Ext. Tooth
12	100541K Tube - Battery Tray	43	STD551125 * Lockwasher 1/4
13	7192J Cable Tie	45	108824X Fuse - 30 Amp.
14	104445X Switch - Interlock - Clutch	46	121433X Ammeter
15	4206J Cable - Battery (Battery to Solenoid)	51	102501X Loop - Wire
16	4406R Ignition Switch	52	235R Clip - Insulated
18	109788X Nut - Ignition	54	106315X Diode Assembly
19	109310X Key	55	4021J Switch PTO
20	109081X Solenoid	56	4022J Nut-Hex
21	110712X Switch - Light	57	109787X Bezel, Ignition
22	73680400 Nut - Hex 1/4 - 20	58	121305X Switch Seat
24	4799J Cable - Battery (Solenoid to Starter)	59	121264X Cap Battery
26	719J Terminal Cover (For Solenoid)	60	121549X Decal Battery
27	4207J Cable - Battery (Battery to Ground)	61	120960X Decal, Battery
		---	124555X Owner's Manual (English)
		---	101539X Sheet, Instruction - Tractor 15° Slope (English)

*STANDARD HARDWARE--PURCHASE LOCALLY

another free manual from www.searstractormanuals.com

REPAIR PARTS

18 HP GARDEN TRACTOR - - MODEL NUMBER 917.254450 & 917.250020

CHASSIS AND ENCLOSURES

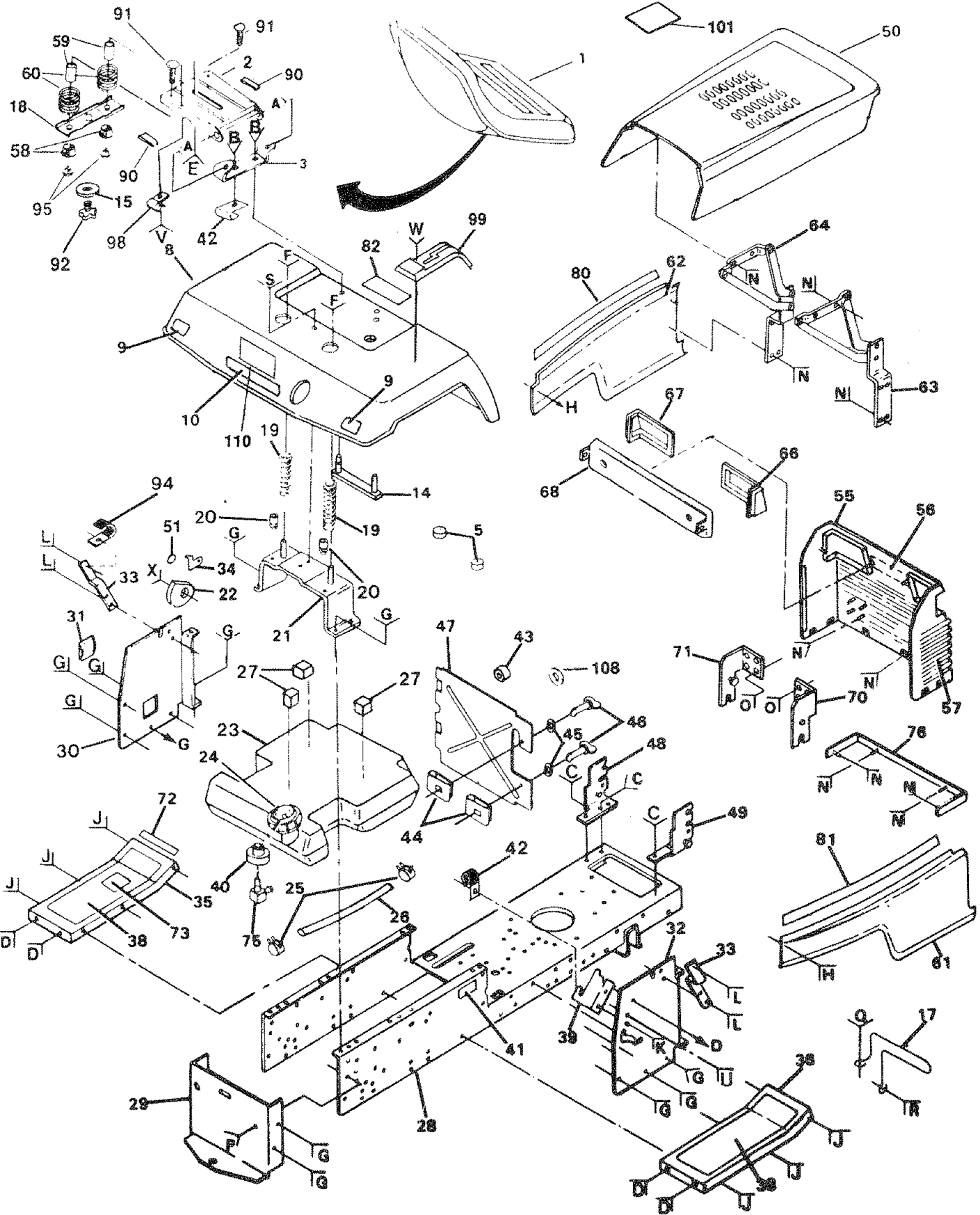

another free manual from www.searstractormanuals.com

REPAIR PARTS

18 HP GARDEN TRACTOR - - MODEL NUMBER 917.254450 & 917.250020

CHASSIS AND ENCLOSURES

NOTE: All component dimensions given in U.S. inches -
1 inch = 25.4 mm

KEY NO.	PART NO.	DESCRIPTION	KEY NO.	PART NO.	DESCRIPTION
1	120066X	Seat	58	121248X	Bushing, Snap
2	121294X	Pan - Seat	59	121249X	Spacer, Split
3	105513X	Bracket - Pivot - Seat	60	121250X	Spring, Compression
4	105529X	Bolt - Shoulder 5/16 - 18	61	108403X	Panel - Side - R.H.
5	124238X	Cap - Spring	62	108410X	Panel - Side - L.H.
6	STD541431	Nut - Lock 5/16 - 18	63	106091X	Hinge - R.H.
7	STD541437	Nut - Lock 3/8 - 16	64	106090X	Hinge - L.H.
8	123784X	Fender	66	106003X	Lens - R.H.
9	106202X	Reflector - Rear	67	106004X	Lens - L.H.
10	105801X	Decal	68	110897X	Bezel - Headlight
11	17490612	Screw, Hex Washer Thd. Roll 3/8-16 x 3/4	70	108512X	Bracket - Pivot - R.H.
12	19131312	Washer 13/32 x 13/16 x 12 Ga.	71	108513X	Bracket - Pivot - L.H.
13	STD523707	*Bolt, Hex, 3/8-16 x 3/4	72	4900J	Decal - Clutch/Brake
14	105511X	Strap - Fender	73	109199X	Decal - Drive Belt
15	19171912	Washer 1 1/32 x 13/16 x 12 Ga.	74	STD523707	Bolt - Hex 3/8-16 x 3/4
16	108885X	Guard - Muffler	75	8710J	Stem - Tank, Fuel
17	121246X	Bracket, Switch - Seat	76	110350X	Strap Assembly - Grill
18	124181X	Compression - Spring R.H.	77	STD522505	Bolt - Hex 1/4 - 20 x 1/2
19	105531X	Nut, Push	78	235R	Clip - Insulated
20	105509X	Bracket - Fender	79	11050600	Washer - Lock, Ext. Tooth 3/8
21	123934X	Scale, Height Indicator	80	106813X	Decal - Stripe, Side Panel, L.H.
22	106020X	Tank - Fuel	81	106814X	Decal - Stripe, Side Panel, R.H.
23	123549X	Cap - Fuel	82	106974X	Decal - Caution
24	123487X	Clamp - Hose	83	17490608	Bolt, Hex Washer Thread Rolling 3/8-16 x 1/2
25	8542R	Line - Fuel	84	19131616	Washer 13/32 x 1 x 16 Ga.
26	106082X	Pad - Spacer	85	19131614	Washer - 13/32 x 1 x 14 Ga.
27	121277X	Chassis Assembly	86	19060718	Washer 3/16 x 7/16 x 18 Ga.
28	123785X	Drawbar	87	106909X	Screw - Special
29	124118X	Panel - Dash - L.H.	88	106910X	Screw - Special
30	121794X	Cover, Access	89	108402X	U-Clip
31	110828X	Panel - Dash - R.H.	90	121251X	Strip, Foam
32	105525X	Bracket - Support - Dash	91	72170410	Bolt, Carr. 1/4 - 20 x 1-1/4
33	123933X394	Pointer, Height Indicator	92	120068X	Knob, Seat
34	105465X	Footrest - L.H.	93	121144X	Shoulder Bolt
35	105464X	Footrest - R.H.	94	5320R	Clip - Insulated
36	STD533707	*Bolt, Carr. 3/8-16 x 3/4	95	123976X	Nut, Hex Large Flange
37	105466X	Pad, Footrest	96	STD511005	Screw - Std. Pan Head #10 - 24 x 1/4
38	110923X	Bracket - Clutch - Mower	97	73951000	Nut, Keps #10 - 24
39	3645J	Bushing	98	4171R	Clip, Insulated
40	105567X	Decal - 6 Speed 44"	99	123825X	Console, Shifter
41	2751R	Clip - Insulated	100	STD523710	Bolt, Fin Hex 3/8 - 16 UNC x 1
42	110436X	Grommet, Split	101	126312X	Decal, Hood
43	105839X	Receptacle	102	10100800	Washer, Lock
44	105838X	Retainer	103	74640806	Screw #8 x 3/8
45	123650X	Stud - 1/4 Turn	104	74780516	Bolt, Hex 5/16 - 18 UNC x 1
46	108105X	Shield - Heat	105	19112410	Washer 11/32 x 1 1/2 x 10 Ga.
47	109015X	Bracket - Pivot - L.H.	106	STD551131	Washer, Lock
48	109016X	Bracket - Pivot - R.H.	107	120529X	Washer, Nylon
49	106013X017	Hood	108	9151R	Grommet
50	123935X	Plug, Hole	109	120597X	Pal Nut
51	73680400	Nut - Crownlock 1/4-20	110	750211	Decal, U.S.A.
52	108067X	Pal - Nut			
53	105528X	Grill			
54	105806X	Decal - Grill			
55	105568X	Decal - Stripe			

another free manual from www.searctractormanuals.com

STANDARD HARDWARE--PURCHASE LOCALLY

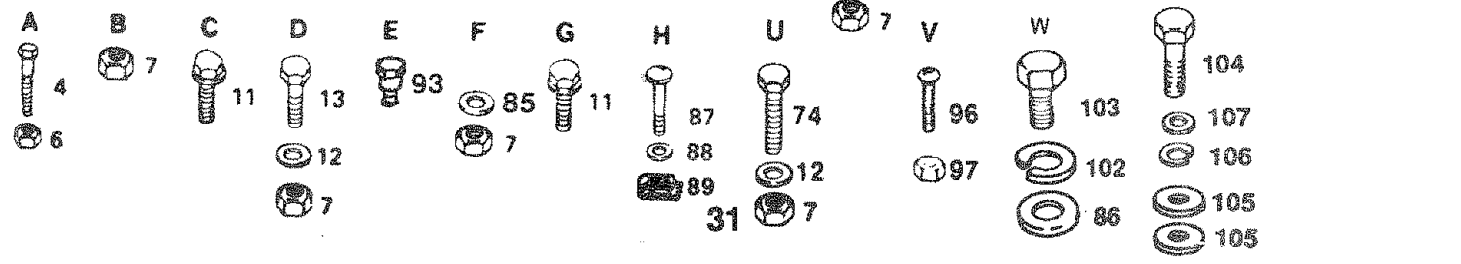

REPAIR PARTS

18 HP GARDEN TRACTOR - - MODEL NUMBER 917.254450 & 917.250020

DRIVE

another free manual from www.searstractormanuals.com

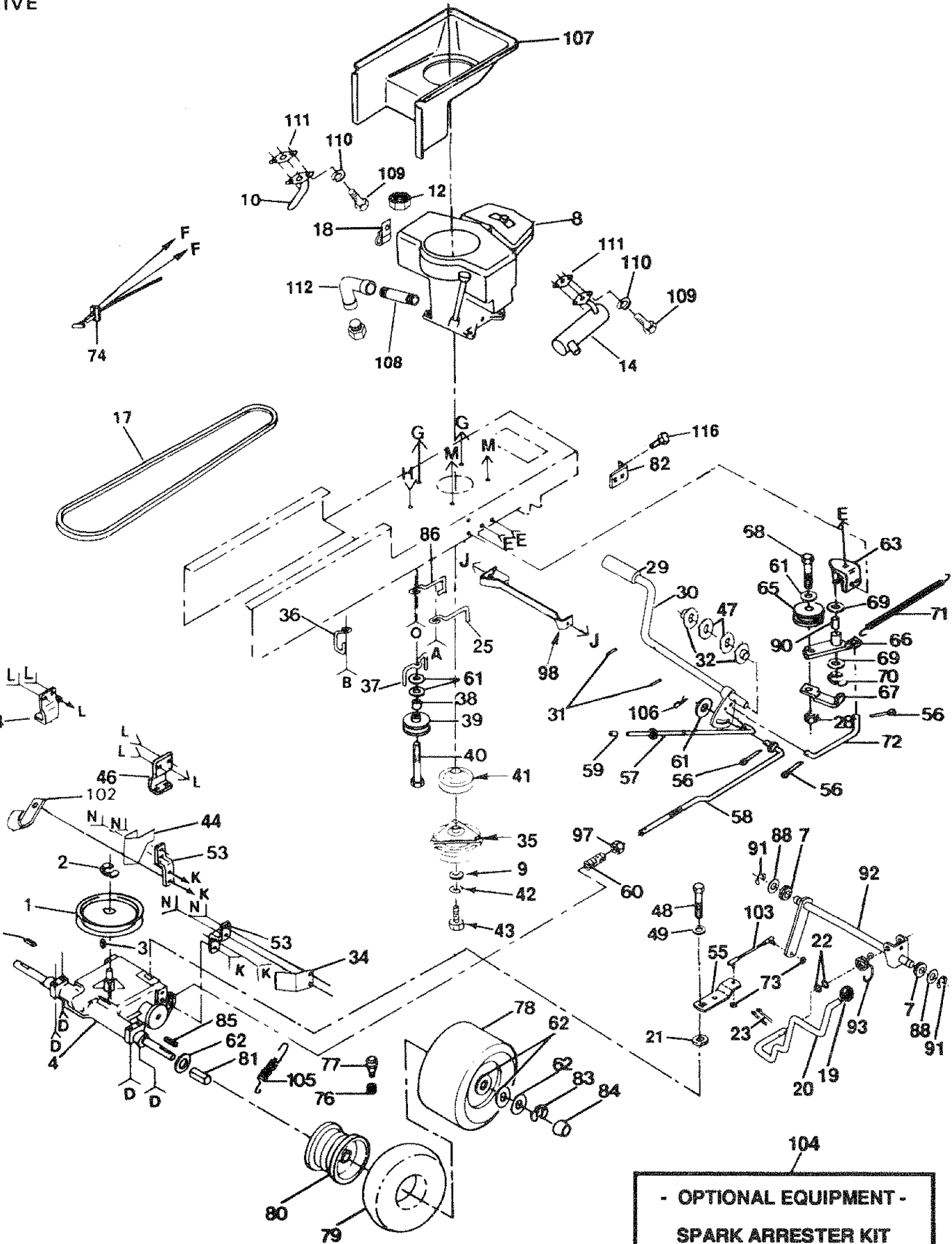

- OPTIONAL EQUIPMENT -
SPARK ARRESTER KIT

REPAIR PARTS

18 HP GARDEN TRACTOR - - MODEL NUMBER 917.254450 & 917.250020

DRIVE

KEY PART NO. NO.	DESCRIPTION	KEY PART NO. NO.	DESCRIPTION
1	121327X Pulley, Transaxle (Driven)	65	123766X Pulley, Idler
2	12000004 Ring, Retainer	66	123789X Arm, Idler
3	2228M Key, Woodruff #9	67	123205X Retainer, Belt
4	123797X Transaxle, 6-Speed, Tecumseh Model No. 143.820-016	68	STD523715 Bolt, Hex 3/8 - 16 x 1-1/2
5	STD533107 Bolt, Hex 5/16 - 18 x 3/4	69	110812X Washer, Hardened
6	19111214 Washer 11/32 x 3/4 x 14 Ga.	70	12000039 Ring, Clip
7	71208 Bushing, Rod, Steering	71	105709X Spring, Return, Clutch
8	125860X Engine, Briggs & Stratton 18 HP Model No. 422707, Type 1227-01	72	105710X Link, Clutch
9	126197X Washer 15/32 x 1-3/4 x 1/4	73	73530400 Nut 1/4 - 28
10	100229L Tube Assembly, Exhaust	74	124559X Control, Throttle
11	17490628 Screw, Hex Wash. Thdrol 3/8 - 16 x 1 3/8	75	17720410 Screw, Hex, Thread Cutting 1/4 - 20 x 5/8
12	STD541437 Nut, Keps 3/8 - 16	76	59192 Cap, Valve
14	108373X Muffler	77	65139 Stem, Valve
17	123796X V-Belt, Drive	78	126609X Tire, Rear
19	106933X Knob	79	7154J Tube (Not furnished with Tractor)
20	123781X Rod, Shifter	80	124074X Rim
21	105701X Washer, Shift Plate	81	108097X Spacer, Split
22	19171216 Washer 17/32 x 3/4 x 16 Ga.	82	108236X Bracket, Switch
23	STD561210 Pin, Cotter 1/8 x 1	83	12000053 E-Ring
24	17490612 Screw, Hex Washer Hd. Thd. Roll. 3/8 - 16 x 3/4	84	104757X Cap Hub, Rear
25	105730X Keeper, Belt, Engine	85	9396E Key Square 1/4 x 2
26	STD523710 Bolt, Hex 3/8 - 16 x 1	86	121218X Keeper, Belt, Engine
27	19131312 Washer 13/32 x 13/16 x 12Ga.	87	17490624 Bolt, Hex, Washer, Thread Rolling 3/8 - 16 x 1-1/2
28	STD541437 Locknut 3/8 - 16	88	19212016 Washer 21/32 x 1 - 1/4 x 16 Ga.
29	8883R Cover, Foot Pedal	89	STD523707 Bolt Hex 3/8 - 16 x 3/4
30	122424X Shaft, Foot Pedal	90	105706X Bearing
31	1572H Pin, Roll 3/16 x 1	91	12000008 Ring, Clip
32	STD551062 Washer 21/32 x 1 x 16 Ga.	92	123772X Shaft Assembly, Shifter
34	123792X Keeper, Belt, Transaxle, R.H.	93	123782X Spring, Torsion
35	126112X Clutch, Electric	94	STD551237 Washer, Lock, Ext. Tooth 3/8
36	123788X Retainer, Belt	97	STD541437 Locknut 3/8 - 16
37	109070X Keeper, Belt	98	109169X Retainer Assembly, Clutch
38	4470J Spacer	101	17490512 Screw, Hex, Washer, Thd. Rolling 5/16 - 18 x 3/4
39	123674X Idler, Flat	102	2751R Clip, Fuel Line
40	STD523727 Bolt, Hex 3/8 - 16 x 2 - 3/4	103	123793X Rod, Tie
41	123795X Pulley, Engine	104	100091X Spark Arrester Kit
42	STD551143 Washer, Lock 7/16	105	110422X Spring, Brake Return
43	74610764 Bolt, Hex 7/16 - 20 x 4	106	4497H Clip, Hair Pin
44	123791X Keeper, Belt, Transaxle, L.H.	107	105953X Duct, Air Intake
46	123776X Bracket Transaxle, R.H.	108	13280336 Nipple, Pipe
47	120183X Bearing Nylon	109	STD522507 Bolt, Hex 1/4 - 20 x 3/4
48	71040412 Bolt, Hex 1/4 - 28 x 3/4	110	STD551125 Washer, Lock 1/4
49	STD551025 Washer 9/32 x 3/4 x 16 Ga.	111	8545J Gasket
51	STD541431 Locknut 5/16 - 18	112	13200300 Elbow, Pipe STD 90°
52	74780544 Bolt, Hex 5/16 - 18 x 2 - 3/4	113	74760516 Bolt, Hex 5/16 - 18 UNC x 1
53	123787X Strap, Torque	114	19111212 Washer 11/32 x 3/4 x 12 Ga.
54	123780X Bracket, Transaxle, L.H.	115	STD541431 Nut, Crownlock 5/16 - 18
55	123794X Shift Arm	116	STD601005 Screw, Tap Hex Hd. #10 - 24 x 1/2
56	STD561210 Pin, Cotter 1/8 x 3/4		
57	125637X Rod, Brake, Park		
58	123786X Rod, Brake		
59	124236X Cap, Plunger		
60	126909X Spring, Rod, Brake		
61	STD551037 Washer 13/32 x 13/16 x 16 Ga.		
62	123800X Washer 1-1/32 x 1 - 5/8 x 16 Ga.		
63	123102X Bracket, Clutch		
64	STD533707 Bolt, Carriage 3/8 - 16 x 3/4		

* STANDARD HARDWARE—PURCHASE LOCALLY

NOTE: All component dimensions given in U.S. inches - 1 inch = 25.4 mm

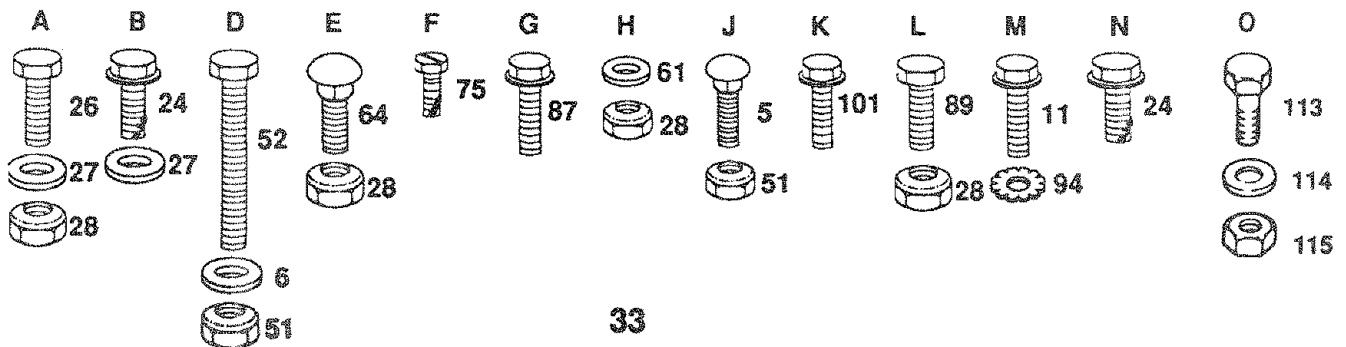

REPAIR PARTS

18 HP GARDEN TRACTOR - - MODEL NUMBER 917.254450 & 917.250020

STEERING ASSEMBLY

KEY NO.	PART NO.	DESCRIPTION	KEY NO.	PART NO.	DESCRIPTION
1	105810X	Decal - Cap, Steering Wheel	46	73901000	Nut, Lock, Flange 5/8-11
2	100710L	Insert, Steering Wheel	47	17490508	Screw, Hex Washer Thd. Rolling 5/16-18 x 1/2
3	73940800	*Nut, Top Lock 1/2 - 20UNF	48	105656X	Spindle, L.H.
4	100712K	Washer	49	105654X	Spindle, R.H.
5	100713N	Wheel, Steering	50	121749X	Washer 25/32 x 1-1/4 x 16 Ga.
6	100711L	*Adapter - Steering Wheel	51	121334X	Rod, Tie
7	110709X	Column - Steering	52	STD551131	*Washer, Lock 5/16
8	120028X	Dash	53	STD541131	*Nut, Hex 5/16-24
9	124557X 011	Dash Plate	54	3366R	Bearing
10	109816X	Nyliner, Snap-In	55	124032X	Link, Drag
11	17490608	Screw, Hex Washer Thd. Rolling 3/8-16 x 1/2	56	STD551137	*Washer, Lock 3/8
12	121748X	Washer 25/32 x 1-5/8 x 16 Ga.	57	STD541137	*Nut, Hex 3/8-24
13	124041X	Shaft, Steering	58	1554J	Bushing, Steering
16	124036X	Bracket, Steering	59	17431008	Screw, Hex No. 10-16 x 1/2
17	124037X	Gear, Pinion	60	104757X	Cap, Hub, Front
18	17490612	Screw, Hex Washer Thd. Rolling 3/8-16 x 3/4	61	2751R	Clip, Fuel Line
19	124033X	Shaft, Pitman	62	STD541037	*Nut, Hex 3/8-16
20	12000029	Klip Ring	63	121232X	Spindle, Cap
21	6266H	Bearing, Thrust	64	59192	Cap, Valve
22	124034X	Gear, Sector	65	65139	Stem, Valve
24	105518X	Dash, Lower	66	6855M	Fitting, Grease
25	74180512	Screw, Crown Truss Hd. 5/16-18 x 3/4	67	9040H	Bearing
26	STD541431	Nut, Lock 5/16-18	68	106732X	Rim, 6" Front
27	123783X 012	Saddle	69	106222X	Tire, Front
28	STD541437	Nut, Lock 3/8-16	71	108456X	Decal, Instructions, Operating
29	STD523120	*Bolt, Hex 5/16-18 x 2	72	59904	Tube, Tire, Front
30	121236X	Spacer	73	72110622	Bolt, Carriage Hex 3/8-16 x 2-3/4
31	106001X	Support Plate, Battery	74	121235X	Spacer
32	STD523707	*Bolt, Hex 3/8-16 x 3/4	75	19131416	Washer 13/32 x 7/8 x 16 Ga.
33	57079	Washer	77	STD512507	*Screw, Pan Head 1/4-20 x 3/4
34	124035X	Shaft, Support	78	19091216	Washer 13/32 x 3/4 x 16 Ga.
35	126684X	Washer 5/8 x 1/4 x 16 Ga.	79	73510400	Nut, Keps 1/4 NC
36	121525X	Control, Choke	80	19272016	Washer 27/32 x 1-1/4 x 16 Ga.
38	STD551237	Washer, Lock, Int./Ext. Tooth 3/8	82	122819X	Screw, Special 3/8 - 16 x 3/4
39	72110608	Bolt, Carriage	84	19111216	Washer 11/32 x 3/4 x 16 Ga.
40	108075X	Axle, Front	86	STD551125	Lockwasher 1/4
41	105663X	Support, Saddle, Rear	87	71070410	Screw, Socket Hex 1/4 x 20 x 5/8
42	74761060	Bolt, Hex 5/8-11 x 3-3/4			
43	105664X	Support, Saddle, Front			
45	110438X	Spacer Bearing, Front Axle			

*STANDARD HARDWARE--PURCHASE LOCALLY

NOTE: All component dimensions given in U.S. inches - 1 inch = 25.4 mm

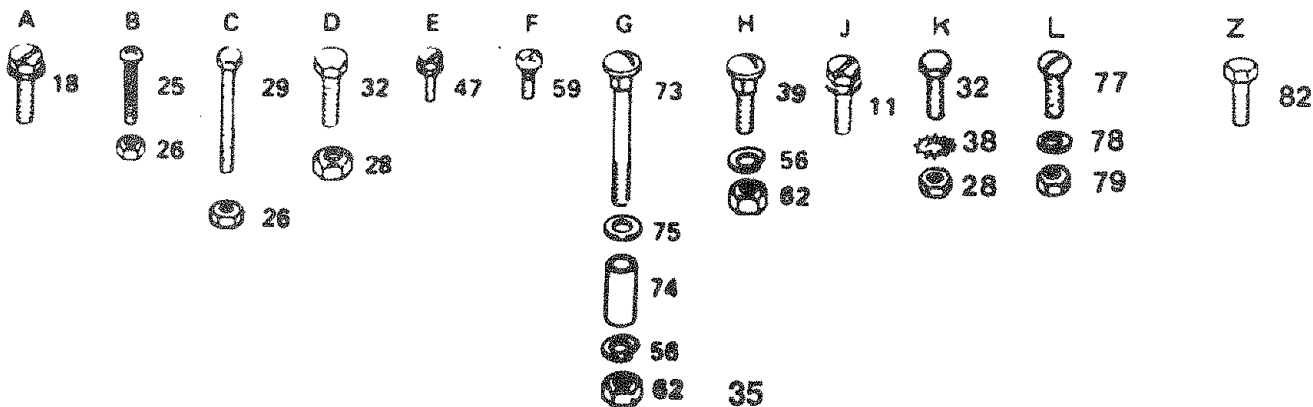

another free manual from www.searstractormanuals.com

REPAIR PARTS

18 HP GARDEN TRACTOR - - MODEL NUMBER 917.254450 & 917.250020

LIFT ADJUSTMENT

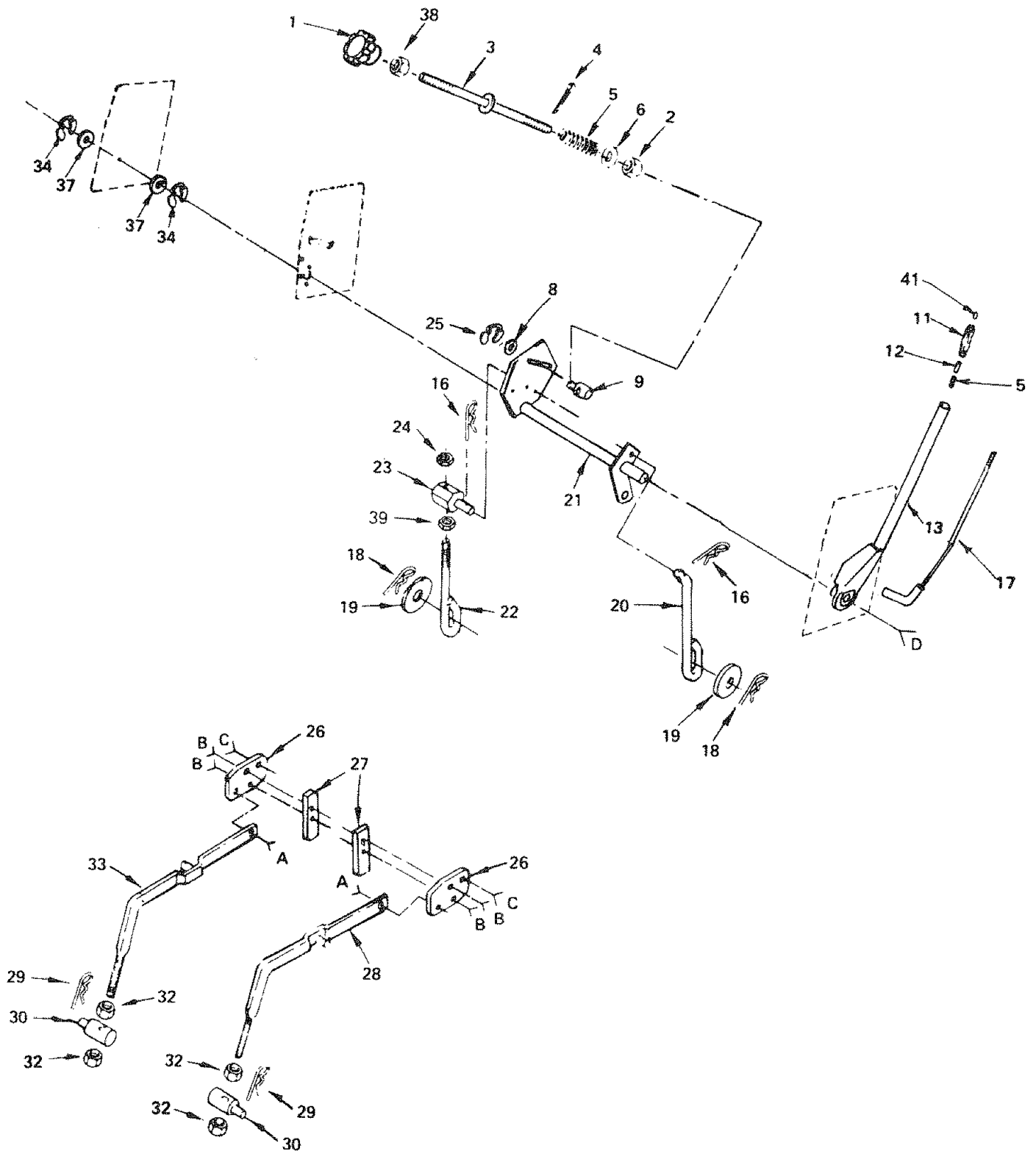

another free manual from www.searstractormanuals.com

REPAIR PARTS

18 HP GARDEN TRACTOR - - MODEL NUMBER 917.254450

MOWER

another free manual from www.searstractormanuals.com

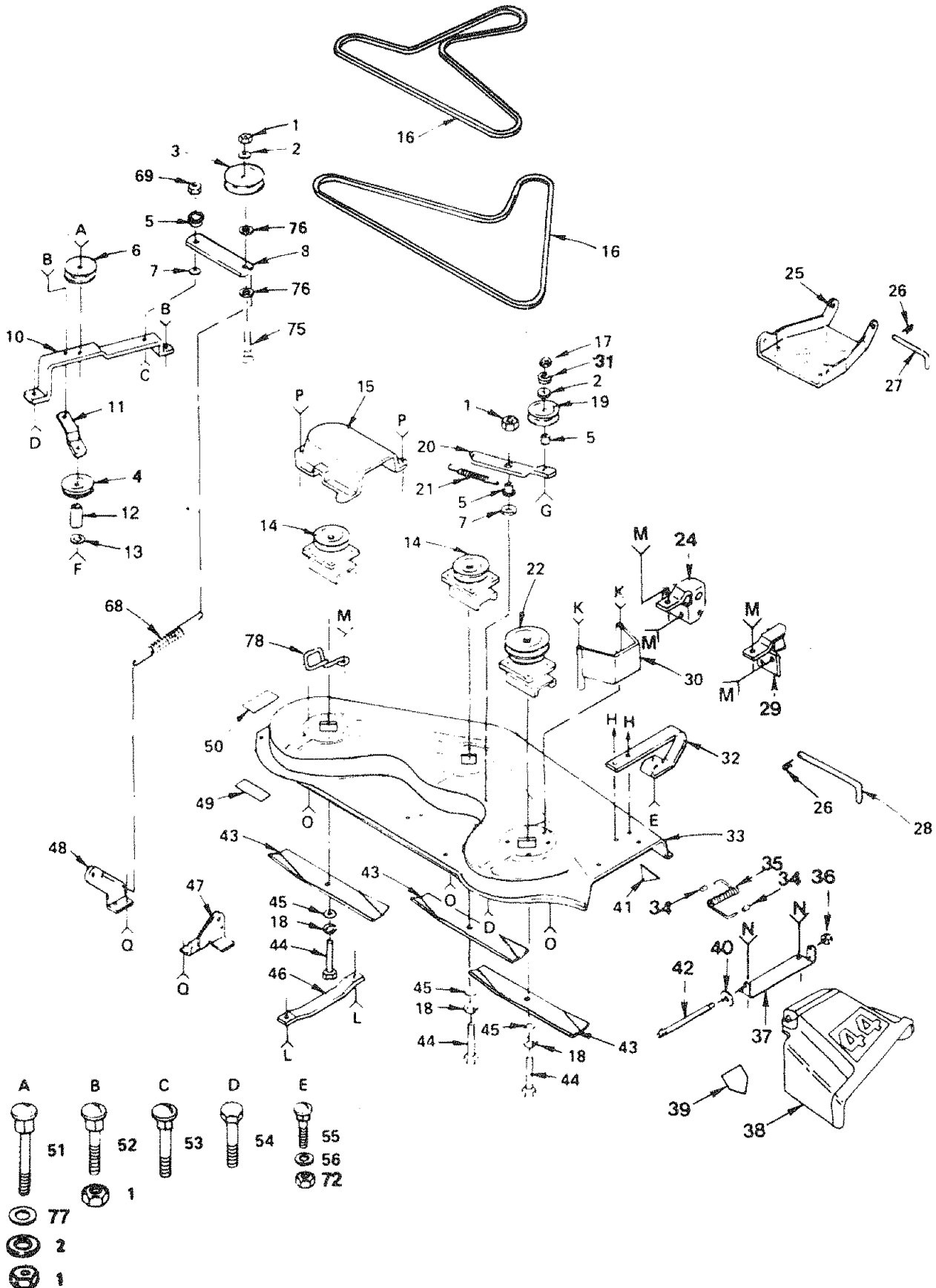

REPAIR PARTS

18 HP GARDEN TRACTOR - - MODEL NUMBER 917.254450 & 917.250020

LIFT ADJUSTMENT

KEY PART NO. NO.	DESCRIPTION	KEY PART NO. NO.	DESCRIPTION
1 121891X	Knob, Depth Adjustment	21 124516X	Shaft - Lift
2 110807X	Nut Hex Special	22 110448X	Link - Lift, Adjust
3 110729X	Rod - Adjust - Lift	23 110447X	Trunnion - Lift
4 STD560907 *	Pin - Cotter 3/32 x 1/2	24 73710700	Nut Lock 7/16 - 20 UNF
5 2876H	Spring	25 12000037	Klip Ring
6 19131016	Washer 13/32 x 5/8 x 16 Ga.	26 105864X	Bracket - Suspension
7 STD541437 *	Nut - Lock 3/8 - 16	27 121252X	Upstop Mower
8 19151216	Washer 15/32 x 3/4 x 16 Ga.	28 121598X	Arm - Suspension - R.H.
9 110810X	Trunnion	29 9135R	Retainer Spring
10 105848X	Bolt, Shoulder 3/8 - 16	30 106308X	Trunnion - Lift - Lower
11 125631X	Grip- Handle	32 STD541050 *	Nut- Hex Fin. 1/2 - 13
12 122364X	Plunger - Lever	33 121599X	Arm - Suspension - L.H.
13 121004X	Lever - Lift (Includes Key No. 17)	34 12000022	E-Ring
14 110739X	Spring Washer	35 STD533710 *	Bolt - Carriage 3/8 - 16 x 1
15 73980600	Center Lock Flangenut 3/8 x 16	36 STD533707 *	Bolt Carriage 3/8 - 16 x 3/4
16 4939M	Retainer - Spring	37 19292016	Washer 29/32 x 1 - 1/4 x 16 Ga.
17 121006X	Rod - Lever	38 STD541237 *	Nut., Hex Jam 3/8 - 16
18 4921H	Retainer - Spring	39 STD541343 *	Nut - Hex Jam 7/16-20
19 19171516	Washer 17/32 x 15/16 x 16 Ga.	40 74780624	Bolt - Hex 3/8 - 16 x 1 - 1/2
20 110029X	Link - Lift	41 122365X	Button - Plunger

*STANDARD HARDWARE—PURCHASE LOCALLY

NOTE: All component dimensions given in U.S. inches -
1 inch = 25.4 mm

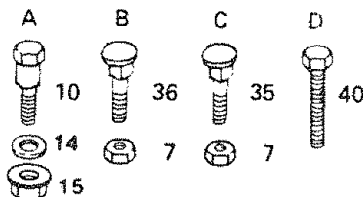

REPAIR PARTS

18 HP GARDEN TRACTOR - - MODEL NUMBER 917.254450

MOWER

KEY PART NO. NO.	DESCRIPTION	KEY PART NO. NO.	DESCRIPTION
1	STD541437 * Nut - Lock 3/8 - 16	40	19111016 Washer 11/32 x 5/8 x 16 Ga.
2	19131614 Washer 13/32 x 1 x 14 Ga.	41	Decal OPEI (not serviced)
3	121316X Pulley Idler	42	106735X Rod Hinge
4	102403X Pulley, Idler	43	106635X Blade
5	106902X Spacer	44	STD623715 * Bolt- Hex 3/8 - 24 x 1- 1/2 Gr. 5
6	677A451 Pulley Idler	45	19132012 Washer 13/32 x 1-1/4 x 12 Ga.
7	106513X Washer - Wear	46	7631J Runner - L.H.
	121425X Arm - Idler	47	123807X Bracket Suspension, Rear-R.H.
	109776X Pin - Pivot		Bracket - Suspension, Rear-L.H.
	106523X Bar Support - Idler	48	123808X Bracket - Suspension, Rear-L.H.
	106522X Brace - Idler - Deck		Decal- V-Belt - Schematic
	121236X Spacer	49	106223X Instruction - Caution Decal
STD551037 *	Washer, 13/32 X 13/16 X 16 Ga.	50	105185X
	Mandrel - Secondary	51	STD533717 * Bolt - Carriage 3/8 - 16 x 1 - 3/4
	121658X Guard	52	STD533710 * Bolt - Carriage 3/8 - 16 x 1
	106214X V Belt	53	STD533715 * Bolt - Carriage 3/8 16 x 1-1/2
106085X		54	STD523712 * Bolt - Hex 3/8 - 16 x 1 - 1/4
STD541037 *	Nut, Hex 3/8 - 16	55	STD533107 * Bolt - Carriage 5/16- 18 x 3,4
STD551137 *	Washer - Lock 3/8	56	STD551031 * Washer 11/32 x 11/16x 16 Ga.
	102932X Idler - Flat	57	STD541431 * Nut - Lock 5/16- 18
	106526X Arm - Idler - Deck	58	STD523730 * Bolt - Hex 3/8 - 16 x 3
	7644J Spring- Extension	59	74110632 Screw - Flat Head 3/8 - 16 x 2
	121705X Mandrel - Primary	61	19111216 Washer 11/32 x 3/4x 16 Ga.
	106511X Bracket Lift L.H.	62	STD523150 * Bolt - Hex 5/16 18 x 5
	105662X Link Parallel	65	STD533107 * Bolt - Carriage 5/16 - 18 x 5/8 UNC x 3/4
	4921H Retainer - Spring		66 17490612 Screw - Hex Washer Thread Rolling 3/8 16 x 3/4
	105744X Pln, Front Hinge	67	STD533707 * Bolt - Carriage 3/8 - 16 x 3/4
	109835X Pin, Rear Hinge	68	102727X Spring - Extension
	106512X Bracket Lift - R.H.	69	STD541437 * Nut - Centerlock 3/8 - 16
	108119X Guard Belt - R.H.	70	STD533107 * Bolt - Carriage 5/16 - 18 x 3/4
STD551137	Washer, Lock Hvy. Hel. Spring	72	1685H Nut - Lock 5/16 - 18
8418J	Runner - R. H.	75	72140620 Bolt, Carriage 3/8 - 16 X 2 1/2
	121423X Housing - Mower	76	19131210 Washer 13/32 x 3/4 x 10 Ga.
	105304X Cap Sleeve	77	STD533106 Washer, 13/32 X 7/8 X 10 Ga.
	106734X Spring	78	121352X Keeper - L.H. Mandrel
	110452X Nut . Push	79	72110505 * Bolt - Carriage 5/16 - 18 X 5/8
	109743X Bracket - Deflector	80	125728X Mower Deck, Complete
	109785X Guard - Discharge		
	121349X Decal - Warning		

* STANDARD HARDWARE--PURCHASE LOCALLY

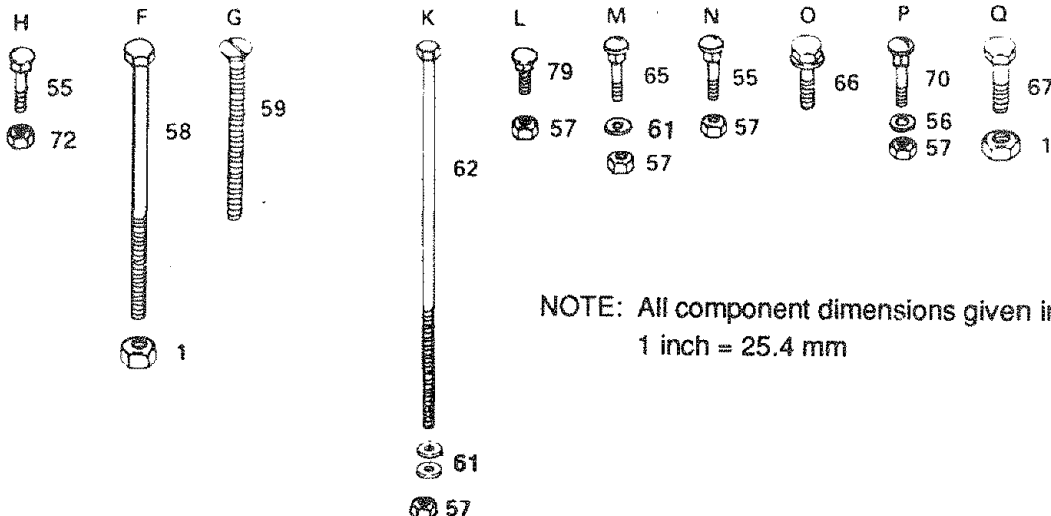

NOTE: All component dimensions given in U.S. inches -
1 inch = 25.4 mm

another free manual from www.seaisrtractormanuals.com

REPAIR PARTS

18 HP GARDEN TRACTOR - - MODEL NUMBER 917.254450 & 917.250020
TRANSAXLE PEERLESS - - MODEL NUMBER 143-820-016

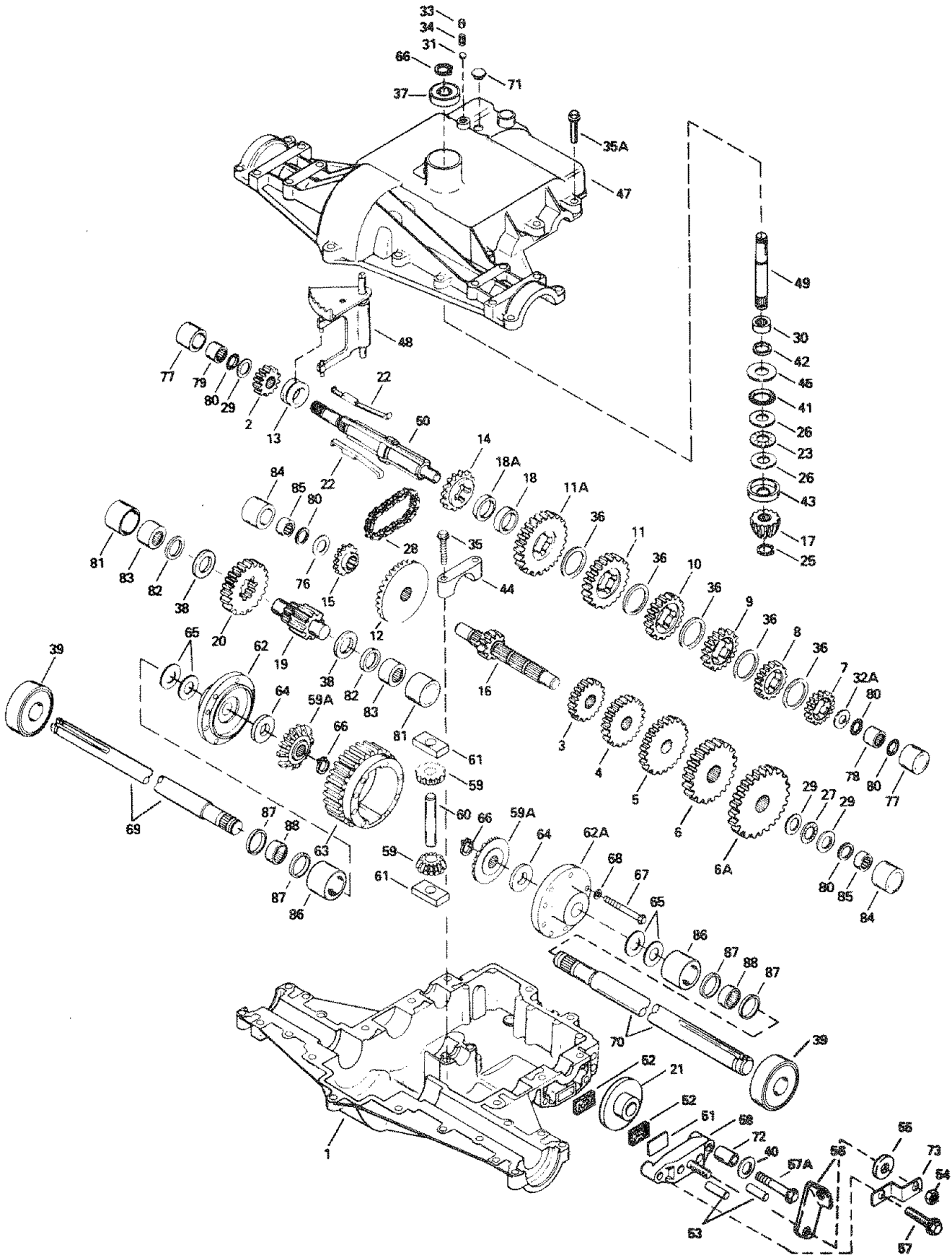

REPAIR PARTS

18 HP GARDEN TRACTOR - - MODEL NUMBER 917.254450 & 917.250020 TRANSAXLE PEERLESS - - MODEL NUMBER 143-820-016

Ref. No.	Part No.	Part Name	Ref. No.	Part No.	Part Name
1	770088	Case, Transaxle	44	786131	Cap, Bearing
2	778253	Gear, Spur (15 teeth)	45	780165	Washer, Flat
3	778211	Gear, Spur (12 teeth)	47	772098	Cover, Transaxle
4	778240	Gear, Spur (18 teeth)	48	784342	Rod & Fork Assy., Shift
5	778201	Gear, Spur (25 teeth)	49	776274	Shaft, Input
6	778202	Gear, Spur (28 teeth)	50	776313	Shaft, Brake (4 Keyed)
6A	778208	Gear, Spur (31 teeth)	51	790007	Plate, Brake pad
7	778209	Gear, Spur (19 teeth)	52	790006	Pad, Brake
8	778203	Gear, Spur (22 teeth)	53	786026	Pin, Dowel
9	778204	Gear, Spur (25 teeth)	54	792075	Locknut, 5/16-24
10	778239	Gear, Spur (32 teeth)	55	792076	Washer, Flat
11	778207	Gear, Spur (37 teeth)	56	790047	Lever, Brake
11A	778216	Gear, Spur (41 teeth)	57	792073	Screw, Flanged hex hd. thread-forming, 1/4-20 x 1-1/4
12	778246	Gear, Bevel (33 teeth)	57A	792085	Screw, Flanged hex hd. thread-forming, 1/4-20 x 2-1/4
13	784216	Collar, Shift	58	790025	Holder, Brake pad
14	786123	Sprocket (18 teeth)	59	778197	Pinion, Differential bevel
15	786082	Sprocket (9 teeth)	59A	778198	Gear, Bevel
16	776291	Shaft, Counter (w/9 tooth gear)	60	786019	Pin, Drive
17	778245	Bevel Pinion, Input (13 teeth)	61	786027	Block, Drive
18	786121	Spacer, Natural (.350/.340 thick)	62	774833	Carrier, Differential (Threaded holes)
18A	786122	Spacer, Natural (.276/.268 thick)	62A	774834	Carrier, Differential
19	776275	Shaft, Output (9 teeth)	63	778248	Gear, Ring (31 teeth)
20	778247	Gear, Output (35 teeth)	64	780107	Washer
21	790043	Disk, Brake	65	780042	Washer, Thrust
22	792138	Key	66	792018	Ring, Snap
23	780084	Bearing, Thrust	67	792020	Screw, Hex hd., 1/4-20 x 2-1/4
25	788040	Ring, Retaining	68	792006	Lockwasher, 1/4"
26	780051	Washer, Thrust	69	774832	Axle (12-5/16" long)
27	780071	Bearing, Thrust	70	774831	Axle (16-3/16" long)
28	786081	Chain, Roller (No. 41 chain, 24 links)	71	792074	Plug, Hex hd., 9/16-18 thread
29	780072	Washer, Thrust	72	786067	Spacer
30	780155	Bearing, Needle	73	786086	Bracket, Brake lever
31	792077	Ball, Steel	76	780153	Washer
32A	780139	Washer, Thrust	77	786144	Sleeve (stepped)
33	792078	Screw, Set, 3/8-16 x 3/8	78	780150	Bearing, Needle
34	792079	Spring	79	780152	Bearing, Needle (capped)
35	792073	Screw, Flanged hex hd. thread-forming, 1/4-20 x 1-1/4	80	792001	"O" Ring
35A	792129	Screw, Hex hd. threadforming, 5/16-18 x 1-1/4	81	786142	Sleeve (stepped)
36	780108	Washer, Thrust	82	788071	Ring, Square cut
37	780119	Bearing, Ball	83	780049	Bearing, Needle (capped)
38	780128	Washer, Thrust	84	786143	Sleeve (stepped)
39	780050	Bearing, Ball	85	780151	Bearing, Needle (capped)
40	792128	Washer, Flat	86	786145	Sleeve (stepped)
41	788077	"O" Ring	87	788070	Ring, Square cut
42	788042	Seal, Oil	88	780031	Bearing, Needle
43	780166	Washer, Cupped			

NOTE: All component dimensions given in U.S. inches.
1 inch = 25.4 mm.

REPAIR PARTS

18 HP GARDEN TRACTOR - - MODEL NUMBER 917.254450 & 917.250020
ENGINE BRIGGS AND STRATTON - MODEL NUMBER 422707, TYPE NUMBER 1228-01
CYLINDER, CRANKSHAFT AND ENGINE BASE GROUP

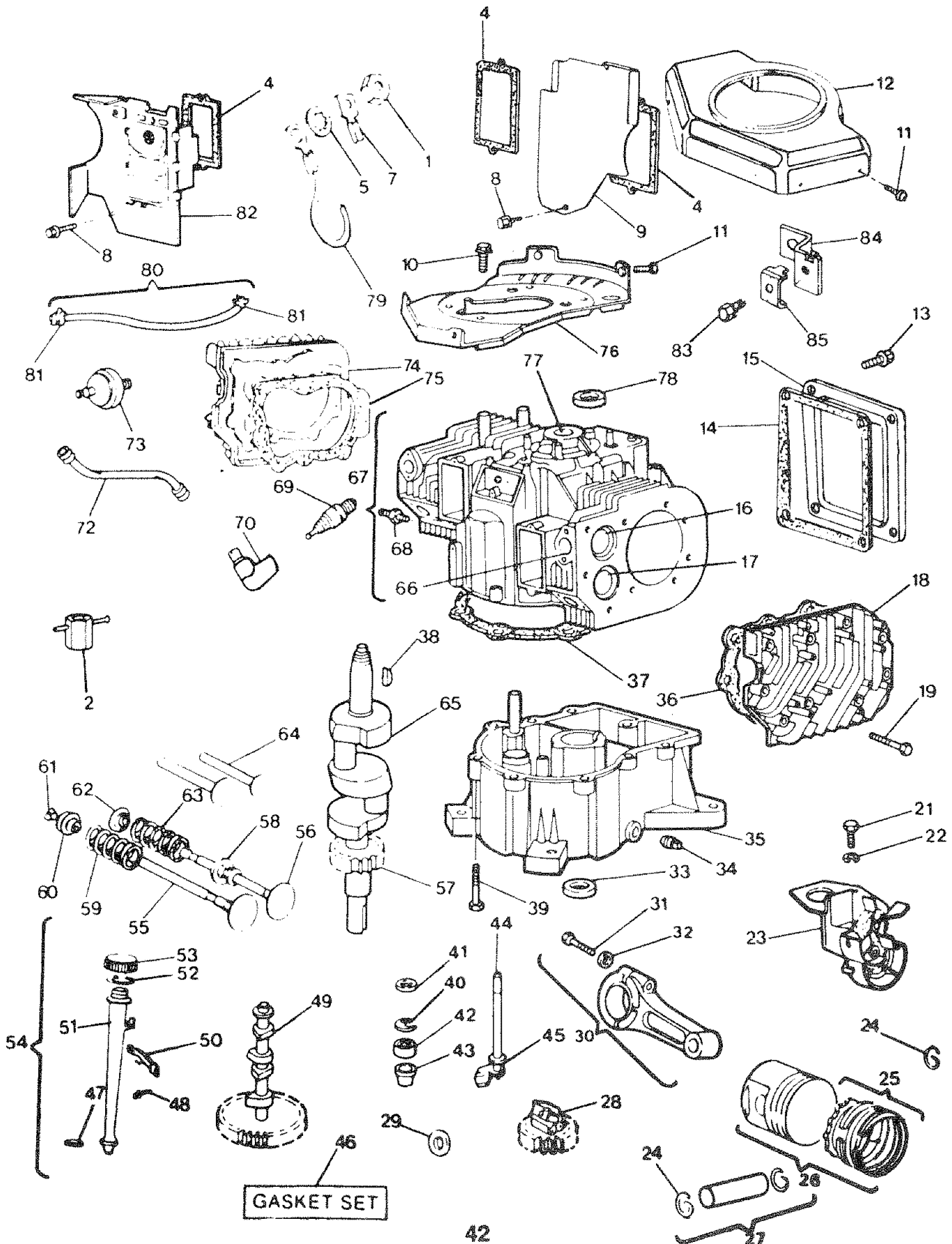

another free manual from www.searstractormanuals.com

REPAIR PARTS

18 HP GARDEN TRACTOR - - MODEL NUMBER 917.254450 & 917.250020

ENGINE BRIGGS AND STRATTON - MODEL NUMBER 422707, TYPE NUMBER 1228-01

CYLINDER, CRANKSHAFT AND ENGINE BASE GROUP

KEY NO.	PART NO.	DESCRIPTION	KEY NO.	PART NO.	DESCRIPTION
1	90576	Nut - Hex 8 - 32	38	222698	Key - Flywheel
2	89838	Wrench, Spark Plug	39	93585	Screw - Hex Hd. Sem
4	27803	*Gasket - Valve Cover	40	94296	Retainer - E-Ring
5	92791	Washer - Lock, Shakeproof	41	491287	Foam Seal - Governor Shaft
6	222892	Cover - Breather Cylinder No. 2	42	262331	Upper Bushing - Governor
	93722	Terminal - Spade	43	262332	Lower Bushing - Governor
	94382	Screw - Sem	44	491530	Crank - Governor
	224362	Baffle - Air	45	223882	Washer - Governor Crank (Inside)
	93777	Screw - Hex Head (Back Plate to Cylinder)	46	394501	Gasket Set
	93559	Screw - Sem	47	271157	Seal - Filler Tube
	492656	Housing - Blower	48	94166	Screw - Hex Head
	90887	Screw - Crankcase Cover Mtg. Sem	49	212337	Gear - Cam
		NOTE: USES 92228 LOCKWASHER	50	222875	Clamp - Oil Filler
	270981	*Gasket - Crankcase	51	280224	Tube - Oil Filler
	212455	Cover Plate - Crankcase	52	271170	Seal - Oil Filler Cap
	261463	+Seat - Intake Valve (Standard)	53	394020	Cap and Dipstick - Oil Filler
	213316	+Seat - Exhaust Valve (Standard)	54	394394	Dipstick and Tube Assembly (Inc. Key Nos. 47, 48, 50, 51, 52 & 53)
	493458	Head - Cylinder No. 2	55	390420	Valve - Exhaust
	94565	Screw - Cylinder Head	56	261528	Valve - Intake
	93686	Screw - Hex Head (10 - 32 x 5/8)	57	231445	Gear - Timing
	92290	Washer - Lock (No. 10 x 1/16 x 3/64)	58	393606	Seal Assembly and Retainer
	393415	Oil Slinger Assembly	59	26828	Spring - Exhaust Valve
	260924	Lock - Piston Pin	60	292260	Rotocoil - Exhaust Valve
	394959	Ring Set - Piston (Standard)	61	93630	Retainer - Exhaust Valve Rotocoil
	394960	Ring Set - Piston (.010" O.S.)	62	221596	Retainer - Intake Valve
	394961	Ring Set - Piston (.020" O.S.)	63	65906	Spring - Intake Valve
	394962	Ring Set - Piston (.030" O.S.)	64	261368	Tappet - Valve *
	394955	Piston Assembly (Standard) (Inc. Key Nos. 24 & 25)	65	394028	Crankshaft
	394956	Piston Assembly (.010" O.S.)	66	261961	NOTE: ORDER NO. 94196 FOR TIMING GEAR RETAINING DEVICE
	394957	Piston Assembly (.020" O.S.)			+Guide - Exhaust Valve
	394958	Piston Assembly (.030" O.S.)			NOTE: 231218 GUIDE INTAKE (BRASS)
	299691	Pin Assembly - Piston (Standard) (Inc. Key No. 24)	67	491730	Cylinder Assembly (Inc. Key No. 68)
	391286	Pin Assembly - Piston (.005" O.S.)	68	230318	Connector - Impulse Pump
	394348	Gear - Governor	69	802592	Plug - Spark (Resistor) Champion RJ-12 or equivalent
	222773	Washer - Thrust	70	66538	Elbow - Spark Plug
	394306	Rod Assembly - Connecting (Inc. Key Nos. 31 & 32)	72	280225	Tube Breather
		NOTE: FOR CONNECTING ROD WITH .020" UNDERSIZE CRANKPIN BORE, ORDER NO. 397158	73	394358	Filter - Fuel (In Fuel Line to Tank)
			74	493457	Head - Cylinder No. 1
1	92909	Screw - Connecting Rod	75	271867	*Gasket - Cylinder
2	220863	Washer	76	491304	Back Plate Assembly
3	291675	Seal - Oil	77	399265	+Bearing - Cylinder
4	91084	Plug - Oil Drain	78	391086	Seal - Oil
5	393552	Base Assembly - Crankcase	79	391115	Wire - Ground
6	271868	*Gasket - Cylinder Head No. 2	80	299146	Line - Fuel (28" cut to required length) (Inc. Key No. 81)
7	271142	*Gasket - Crankcase Cover (1/64" thick)	81	93053	Clamp - Fuel Line
7	271188	*Gasket - Crankcase Cover (.005" thick)	82	393370	Breather Assembly No. 1
7	271189	*Gasket - Crankcase Cover (.009" thick)	83	93496	Screw - Hex Head
			84	223890	Bracket - Choke Cable
			85	221535	Clamp - Casing

NOTE: All component dimensions given in U.S. inches.
1 inch = 25.4 mm.

*INCLUDED IN GASKET SET 394501
+SPECIAL TOOLS REQUIRED TO INSTALL

another free manual from www.searctractormanuals.com

REPAIR PARTS

18 HP GARDEN TRACTOR - - MODEL NUMBER 917.254450 & 917.250020
 ENGINE BRIGGS AND STRATTON - MODEL NUMBER 422707, TYPE NUMBER 1228-01

AIR CLEANER - CARBURETOR GROUP

another free manual from www.searstractormanuals.com

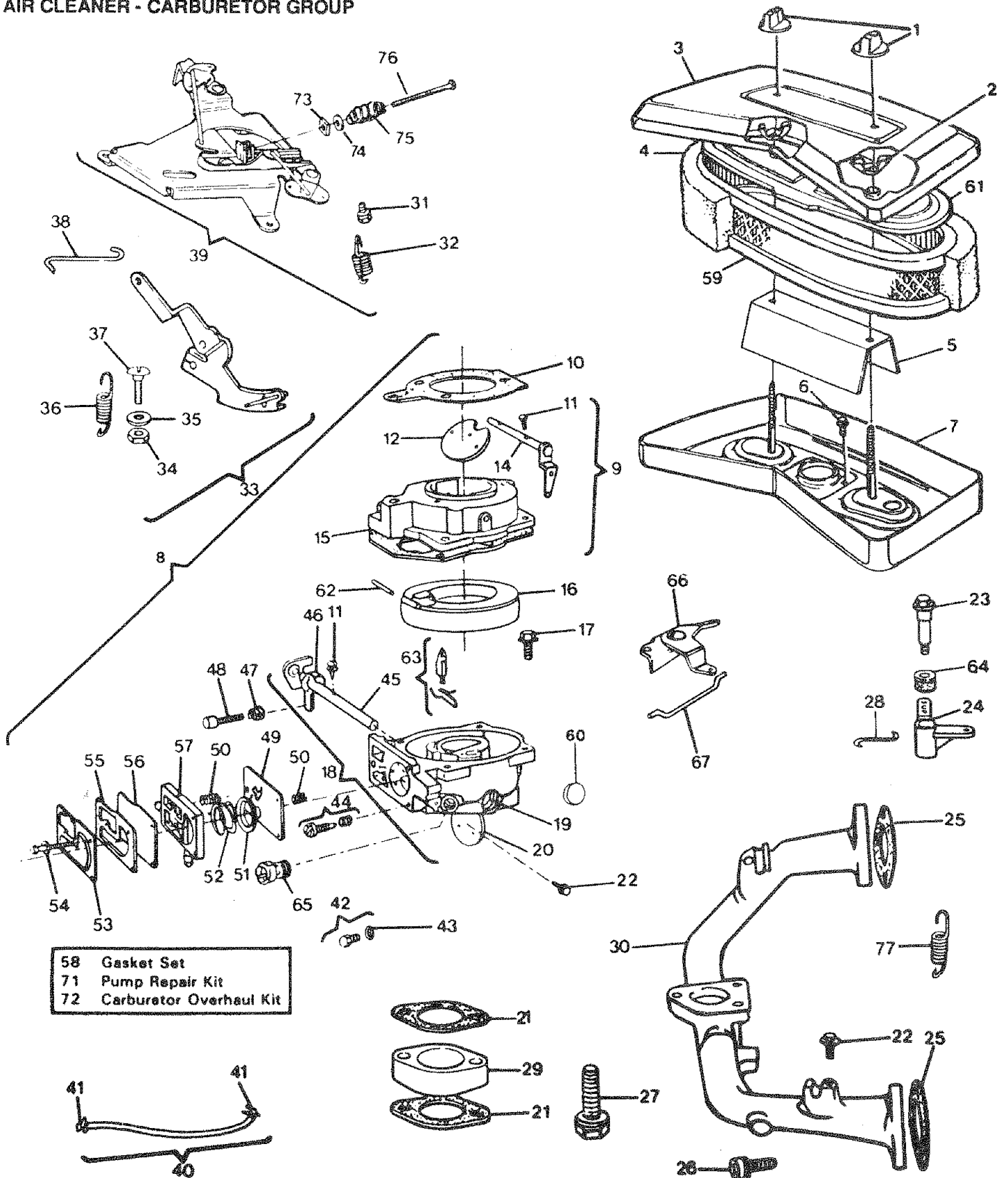

- | | |
|----|-------------------------|
| 58 | Gasket Set |
| 71 | Pump Repair Kit |
| 72 | Carburetor Overhaul Kit |

REPAIR PARTS

18 HP GARDEN TRACTOR - - MODEL NUMBER 917.254450 & 917.250020
ENGINE BRIGGS AND STRATTON - MODEL NUMBER 422707, TYPE NUMBER 1228-01

AIR CLEANER - CARBURETOR GROUP

KEY NO.	PART NO.	DESCRIPTION	KEY NO.	PART NO.	DESCRIPTION
1	212706	Knob - Air Cleaner	38	262683	Link - Governor
2	94289	Nut - Hex	39	491282	Plate Assembly - Governor Control
3	223579	Cover - Air Cleaner	40	393815	Impulse Line and Clamp Assembly (Inc. Key No. 41)
4	271271	Element - Air Cleaner	41	93053	Clamp - Fuel Line
5	224039	Mounting Strap Assembly - Air Cleaner	42	397882	Plug and Seal, Solenoid
	94166	Screw - Hex Head	43	280474	O-Ring Seal
	398826	Body - Air Cleaner	44	491538	+ Valve Assembly - Carburetor Idle
	491429	Carburetor Assembly (Inc. Key Nos. 9, 10, 11, 12, 13, 14, 15, 16, 17, 18, 19, 20, 42, 43, 44, 45, 46, 47, 48, 49, 50, 51, 52, 53, 54, 55, 56, 57, 62 & 63)	45	392672	Shaft and Lever - Throttle
	491541	Body Assembly - Upper Carburetor	46	271013	+ Washer - Choke Shaft
	271411	Gasket - Air Cleaner	47	26157	Spring - Throttle Adjustment
	93499	Screw - Throttle and Choke	48	91920	Screw - Machine Fill. Hd. (8 - 32 x 5/8)
	223534	Valve - Choke	49	270988	x Diaphragm
	392673	Shaft and Lever - Choke	50	261358	x Spring
	271607	+ Gasket - Carburetor Body	51	221377	x Cap - Spring
	298514	Float - Carburetor	52	261395	x Spring - Pump
	94152	Screw - Hex Head Sem (10 - 32 x 3/4)	53	223688	Cover - Diaphragm
	491543	Body - Lower Carburetor (Inc. Key Nos. 11, 19, 20, 45 & 46)	54	93829	Screw - Diaphragm - Damping
	231209	Bushing - Throttle Shaft	55	271025	x Gasket - Carburetor Pump
	221939	Valve - Throttle	56	270989	x Diaphragm - Damping
	271412	+ * Gasket - Carburetor and Intake Elbow	57	280197	Body - Pump
	93897	Screw - Sem	58	394501	Gasket Set
	93971	Screw - Hex Head	59	394019	Cartridge - Air Cleaner
	280997	Crank - Bell	60	223472	Plug - Welch
	270884	* Gasket - Intake Manifold Mounting	61	223714	Cartridge Plate - Air Cleaner
	93208	Screw - Intake Manifold Mounting	62	230896	+ Pin - Float Hinge
	93970	Screw - Hex Head	63	394683	+ Valve - Fuel Inlet
	262684	Link - Throttle	64	271013	Washer
	280319	Spacer - Carburetor	65	231338	° Jet - Needle Valve (Fixed)
	213290	Manifold Assembly - Intake	66	490207	Crank - Bell
	93949	Screw - Sem	67	262375	Link
	262351	Spring - Governor	71	393397	Repair Kit - Pump
	491297	Lever Assembly - Governor (Inc. Key Nos. 34, 35 & 37)	72	491539	Overhaul Kit - Carburetor
	92278	Nut - Hex (10 - 24)	73	94298	Nut - Square
	222289	Washer	74	223882	Washer
	261563	Spring - Governor Idle	75	262337	Spring - Compression
	93853	Bolt - Governor Lever	76	94297	Screw - Pan Head
			77	262539	Spring, Gov. Control

NOTE: All component dimensions given in U.S. inches.
 1 inch = 25.4 mm.

*INCLUDED IN GASKET SET 394501
 +INCLUDED IN CARBURETOR OVERHAUL KIT
 491539
 xINCLUDED IN CARBURETOR OVERHAUL KIT
 491539 AND PUMP REPAIR KIT 393397
 °HIGH ALTITUDE — JET NEEDLE
 VALVE — PART NO. 231333

REPAIR PARTS

18 HP GARDEN TRACTOR - - MODEL NUMBER 917.254450 & 917.250020
ENGINE BRIGGS AND STRATTON - MODEL NUMBER 422707, TYPE NUMBER 1228-01
ALTERNATOR AND STARTER MOTOR GROUP

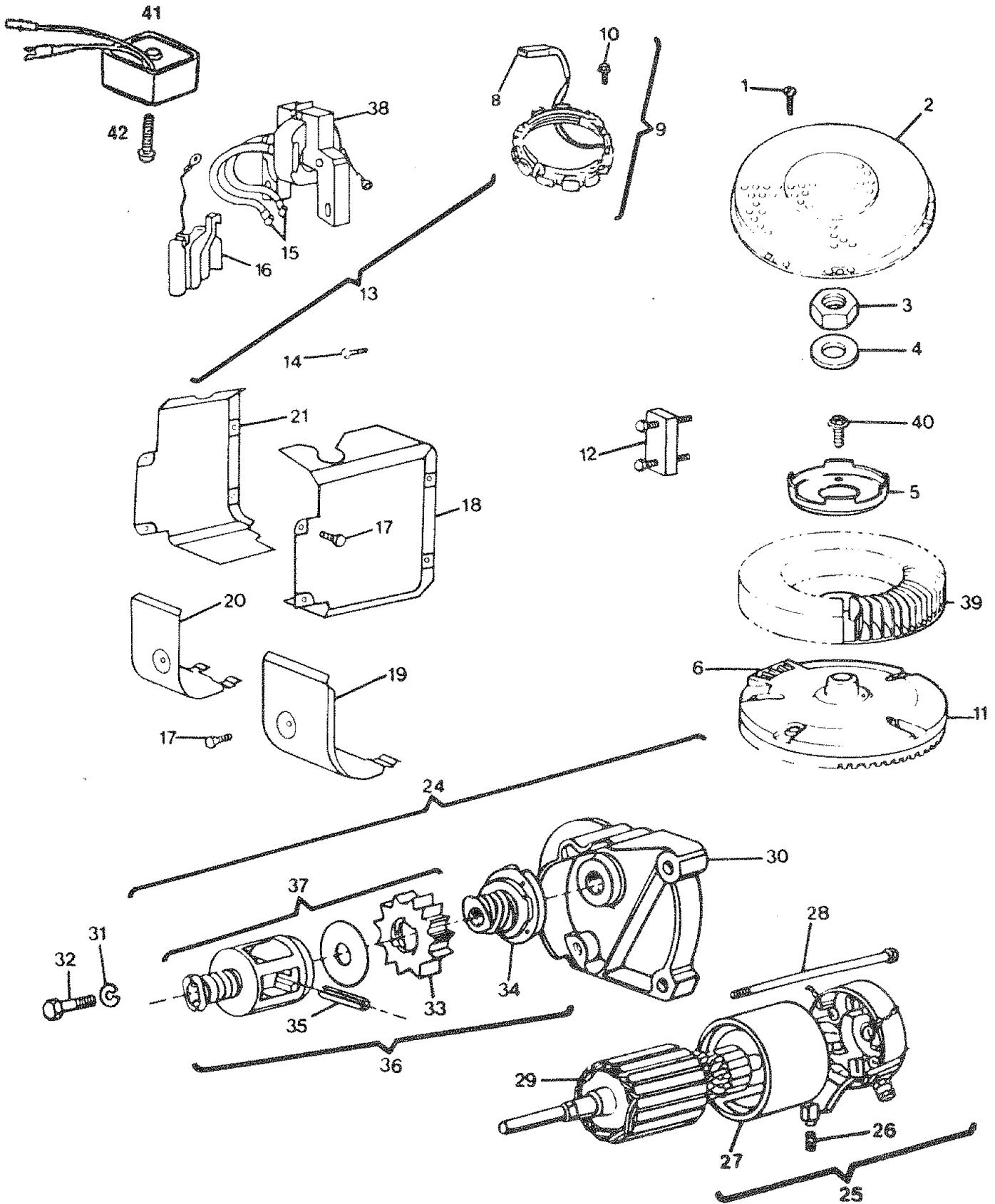

REPAIR PARTS

18 HP GARDEN TRACTOR - - MODEL NUMBER 917.254450 & 917.250020

ENGINE BRIGGS AND STRATTON - MODEL NUMBER 422707, TYPE NUMBER 1228-01

ALTERNATOR AND STARTER MOTOR GROUP

KEY NO.	PART NO.	DESCRIPTION	KEY NO.	PART NO.	DESCRIPTION
1	94326	Screw - Sem	21	222848	Cover - Air Guide
2	222673	Screen - Flush Rotating	24	394808	Motor - Starting (Inc. Key Nos. 25, 26, 27, 28, 29, 30, 33, 34, 35, 36 & 37)
3	230674	Nut - Hex	25	395537	Commutator End Cap Assembly Starter (Inc. Key No. 26)
4	222511	Washer - Spring	26	395538	Brush Set
5	223726	Retainer - Fan	27	393825	Housing Assembly
	491179	Flywheel and Ring Gear Assembly - Magneto	28	94003	Thru Bolt
	393537	Diode and Connector Assembly	29	390837	Armature Assembly (Motor)
	392595	Stator - Alternator (Dual Circuit) (Inc. Key No. 8)	30	394860	Drive End Cap Assembly - Starter
	93621	Screw - Sem	31	90366	Lockwasher
	391362	Gear - Flywheel Ring (Includes Mounting Parts)	32	91162	Screw - Hex Head (5/16 - 18 x 1-1/2)
	19203	Puller - Flywheel (Optional Accessory)	33	280104	Gear - Starter
	394891	Armature Group (Inc. Key Nos. 15, 16 & 38)	34	398003	Clutch Assembly - Starter
	93381	Screw - Armature Mounting Sem	35	94288	Roll Pin
	221798	Terminal - Ignition Cable	36	490421	Pinion Spring Kit (Inc. Key Nos. 33 & 35)
	394970	Trigger Coil Assembly Magnatron Ignition	37	490467	Starter Drive Group (Inc. Key Nos. 33, 34, 35 & 36)
	93163	Screw - Sem	38	394988	Armature Assembly
	222849	Cover - Air Guide	39	280815	Fan - Flywheel
	222734	Shield - Cylinder	40	93535	Screw - Sem
	222846	Shield - Cylinder	41	491546	Regulator, Alternator
			42	94137	Screw, Regulator

NOTE: All component dimensions given in U.S. inches.
1 inch = 25.4 mm.

another free manual from www.searstractormanuals.com

Attachments That Add to the Usefulness of Your Craftsman Garden Tractor

Sears offers a wide variety of attachments that fit your tractor. Many of these are listed below with brief explanations of how they can help you. This list was current at the time of publication; however, it may change in future years — more attachments may be added, changes (including changes in the stock number) may be made in these attachments, or some may no longer be available.

Most of these attachments do not require additional hitches or conversion kits (those that do are indicated) and are designed for easy attaching and detaching. You may order these attachments at most Sears retail stores, catalog sales offices, and through the catalog.

LAWN SWEEPERS let you collect grass clippings and leaves.

Stock No.	Path	Capacity
71-24030	30-in.	9.0 cu. ft.
71-24032	32-in.	10.0 cu. ft.
71-24033 High-Performance	32 in.	11.5 cu. ft.
71-24038	38-in.	12.5 cu. ft.

LAWN VACS for powerful collections of heavy grass clippings and leaves. All accept Wand attachment to pick up debris in hard-to-reach places.

Stock No.	Engine	Capacity	Also Required
71-2455	3HP	8 bu.	71-26471 chute
71-2452	3HP	12 bu.	71-26471 chute
71-2447	5HP	25bu.	71-24474 chute

CARTS make hauling easy.

Stock No.	Size	Capacity	
71-24353	4 cu. ft.	400 lb.	Dump cart
71-24354	10 cu. ft.	1,000 lb.	Hauling cart
71-24355	10 cu. ft.	1,000 lb.	Dump cart
71-24356	14 cu. ft.	1,250 lb.	Dump cart
71-24357	17 cu. ft.	1,500 lb.	Dump cart

ROLLER for smoother lawn surface. 36-inch wide, 18 inch diameter water-tight drum holds up to 390 lb. of weight. Rounded edges prevent harm to turf. Adjustable scraper automatically cleans drum. Stock number 71-24084.

SPREADER/SEEDERS make seeding, fertilizing, and weed killing easy. Broadcast spreaders are also useful for granular de-icers and sand.

- 71-24194 Drop type, 36 inch. 12 in. semi-pneumatic wheels. 100 lb. capacity steel hopper.
- 71-24394 Broadcasts over a 5 to 8 foot swath. 70 lb. capacity steel hopper. Noncorrosive spreading spinner, nylon gear box, stainless steel shaft.
- 71-24395 Broadcasts 8 to 10 foot swath. 160 lb. capacity. (covers 40,000sq. ft.) No-rust polypropylene hopper and impeller. Vinyl hopper cover.
- 71-2416 Broadcasts 6 to 8 foot swath. 50 lb. capacity. Corrosion-resistant construction. Polyethylene hopper.

CORING AERATOR takes small plugs out of soil to allow moisture and nutrients to reach grass roots. 36-inch swath. 24 hardened steel coring tips. 150 lb. capacity weight tray. Stock number 71-24351

AERATOR promotes deep root growth for a healthy lawn. Tapered 2.5" steel spikes mounted on 10-in. diameter discs puncture holes in soil at close intervals to let moisture soak it. Steel weight tray for increased penetration. Stock number 71-2435.

DETHATCHER loosens and flips thatch and matted leaves to lawn surface for easy pick up. Twenty spring tine teeth. Useful to prepare bare areas for reseeding. 40 inch rear mount: Stock number 71-24313. 38 inch front mount: Stock number 71-24301.

SPRAYERS use 12-volt DC electric motor that connects to the tractor battery or other 12-volt source. Includes booms for automatic spraying when pulling, and hand held wand for spot spraying. Wand has adjustable spray pattern. For applying herbicides, insecticides, fungicides, and liquid fertilizers.

- 71-2458 50 psi maximum pressure with 25 foot wand length. Sprays up to 25 feet with wand.
- 71-24398 25 psi maximum pressure with 18 foot wand length. Sprays up to 18 feet with wand.

DOZER BLADE removes snow, grades dirt, sand and gravel. 48 inches wide, 17 inches high, clears 44 inch path when angled. Master lift control lever for operator ease. Spring trip for snow removal on uneven pavement; built - in float for blade to follow ground contour. Reversible, replaceable scraper bar. (Use with tire chains, wheel weights or rear drawbar weight). Stock No. 71-244010

NOWTHROWER has 40-inch swath. Drum-type auger handles powdery and wet/heavy snow. Mounts easily with multiple pin arrangement. Discharge chute adjusts to 240 degree arc from tractor seat. 6-inch diameter spout discharges snow 10 to 50 ft. Lift controlled at tractor seat. (Use with tire chains, wheel weights, or rear drawbar weight). Stock No. 71-24077.

TIRE CHAINS are heavy duty; closely spaced extra-large cross links give smooth ride, outstanding traction. Stock No. 71-26945.

HEEL WEIGHTS provide stability, reduce tearing of turf when moving on hills, stopping, turning, starting. Provides extra weight for traction to pull low-loads, lawn vac. Required for snow removal. For plowing: one in front frame, one in front rear tire, two on left rear tire. For snow blower or dozer blade: one on right rear tire, one on left rear tire. 55 pounds. Stock No. 71-26234. (Front or rear mounting frame bracket Stock No. 71-244360 OR 262235).

HEVRON TIRES for extra traction. Pair of rear tires mounted on wheels. Stock No. 71-24166.

TRACTOR CAB has heavy duty vinyl fabric over tubular steel frame, fiberglass top; clear plastic windshield offers 360 degree visibility. Hinged metal frame doors with catch. Keeps operator warm and dry. Remove vinyl and windshield for use as sun protector in summer. Stock No. 71-24172

Additional accessories for tractor cab: tinted/tempered solid safety glass windshield with hand operated wiper (Stock No. 71-26168); 12-volt amber caution light for mounting on cab top (Stock No. 71-26169).

TRACTOR COVER protects tractor from weather. Made of Evolution 3 fabric (water-repellent, extremely breathable, lightweight, soft, non-abrasive, pliable in all temperatures, durable, stain-tear-puncture resistant, will not shrink or stretch). Stock No. 71-24602.

TILLER has 8hp engine to prepare seed beds, cultivate and compost garden residue. Chain-drive transmission. Six 1 1/2 inch dia., one piece heat-treated steel tines. Tills 30 inch path. (Requires sleeve hitch Stock No. 71-25231.) Stock No. 71-25249.

ROW turns soil 6 inches deep, cuts 10 inch furrow. Crank adjustment controls depth, 3-position yoke sets width. Heavy duty landslide for straight forrowing. Stock No. 71-24233.

DISC HARROW has 2 gangs of 4 steel blades that angle from 10 to 20 degrees 40 inches wide. Can hook 2 units in tandem. Stock No. 71-24234.

FRONT GRADER/LEVELER BLADE is 42-inches wide operated from driver's seat. Reversible steel blade can be angled 10 degrees for grading. Reverses for snow plowing. Stock No. 71-24239.

FRONT CULTIVATOR is 43 inches wide. Prepares ground for seeding, helps weed control. Steel frame holds 5 interchangeable sweeps. Adjusts vertically, horizontally, Stock No. 71-25304. Optional accessory for cultivator: steel forrow opener for wider for wide openings for potatoes, corn, and other deep seeded crops (Stock No. 71-25305).

FRONT BRACKET for drawbar for snow removal applications. Can be mounted on front of tractor for plowing applications. Uses (1) 55 lb. weight - number 71-244360.

Interlocked attachments require sleeve hitch (Stock No. 71-24235) for use with master lift system. Single pin couples/couples.

SERVICE NOTES

SUGGESTED GUIDE FOR SIGHTING SLOPES FOR SAFE OPERATION

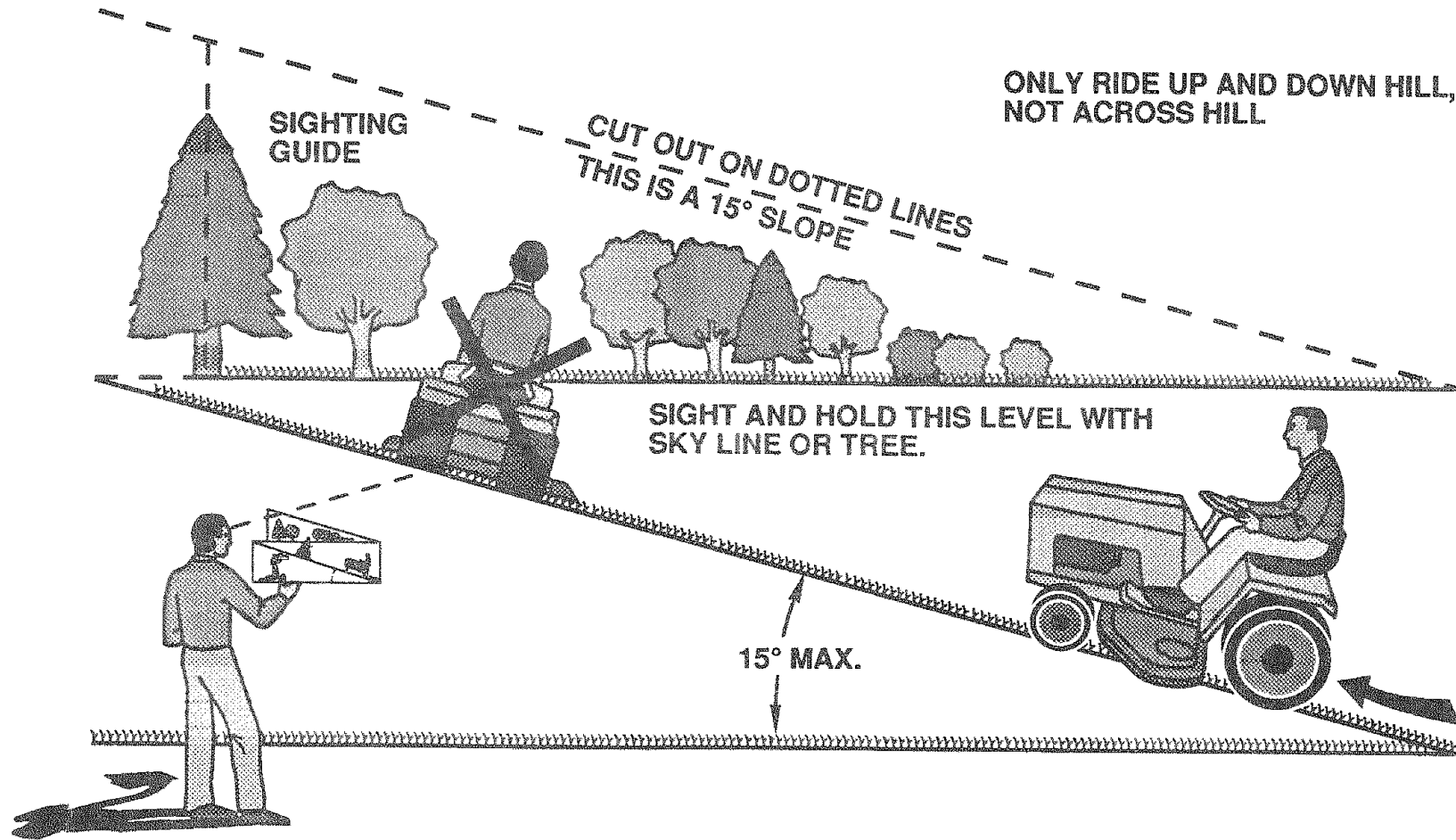

 **Operate your Tractor up and down the face of slopes (not greater than 15°) never across the face. Make turns gradually to prevent tipping or loss of control. Exercise extreme caution when changing direction on slopes.**

SEARS

OWNER'S MANUAL

**MODEL NO.
917.254450
AND
917.250020
WITHOUT
MOWER DECK**

HOW TO ORDER REPAIR PARTS

CRAFTSMAN[®]

18.0 HP TWIN IC ELECTRIC START 44" MOWER DECK 6 SPEED TRANSAXLE GARDEN TRACTOR

Each Tractor has its own model number. Each Engine has its own model number.

The model number for your Tractor will be found on the Model Plate located under the seat.

The model number for your Engine will be found on the Blower Housing.

All parts listed herein may be ordered from any Sears, Roebuck and Co. Service Centers and most Retail Stores.

WHEN ORDERING REPAIR PARTS, ALWAYS GIVE THE FOLLOWING INFORMATION:

- PRODUCT - 18 H.P. GARDEN TRACTOR
- MODEL NUMBER - 917.254450
- ENGINE MODEL NUMBER -422707, TYPE NUMBER 1227-01
- PART NUMBER
- PART DESCRIPTION

Your Sears merchandise has added value when you consider Sears has service units nationwide staffed with Sears trained technicians... professional technicians specifically trained to insure that we meet our pledge to you, we service what we sell.

Sears, Roebuck and Co., Chicago, IL 60684 U.S.A.